

Yale

Electric Trolley Model VTE/F-U

with Shackle Suspension
Capacity 1000 - 5000 kg

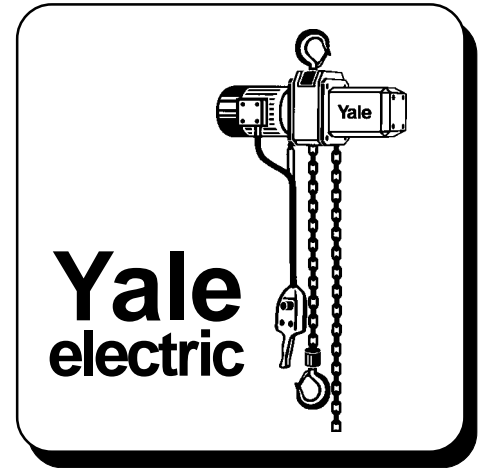

Operating and Maintenance Manual Spare Parts Catalog

Yale

Yale Industrial Products GmbH

P. O. Box 10 13 24 • D-42513 Velbert, Germany
Am Lindenkamp 31 • D-42549 Velbert, Germany
Tel. 2051-600-0 • Fax 2051-600-127

Ident.-Nr. 09900397 / 04.01

TABLE OF CONTENTS

1. INTRODUCTION

2. OPERATING INSTRUCTIONS

2.1 Correct operation

- Maximum capacity
- Danger zones
- Attaching the trolley
- Temperature range
- Regulations
- Maintenance / repair

2.2 Incorrect operation

2.3 Initial operation

- Inspection before initial operation
- Inspection before starting work
- Inspection of traverse
- Check adjustment of trolley width

2.4 Electrical connection

- Preparation
- Mains supply connection

2.5 Function / operation

- Assembly instruction

2.6 Traversing the trolley

2.7 Inspection / service

- Regular inspections

1. INTRODUCTION

Attention: All users must read these operating instructions carefully prior to initial operation. These instructions are intended to acquaint the user with the electric winch and enable him to use it to the full extent of its intended capabilities.

The operating instructions contain important information on how to handle the electric winch in a safe, correct and economic way. Acting in accordance with these instructions helps to avoid dangers, reduce repair costs and down time and to increase the reliability and lifetime of the electric winch. These operating instructions have to be always available at the place where the winch is used. Anyone involved in doing any of the following work with the electric winch must read the operating instructions and act accordingly:

- operation, including preparation, trouble shooting during operation and cleaning maintenance
- inspection and repair and / or
- transport

Apart from the operating instructions and the accident prevention act valid for the respective country and area where the winch is used, also the commonly accepted regulations for safe and professional work must be adhered to.

2. OPERATING INSTRUCTIONS

2.1 Correct operation

Maximum capacity

- The Yale electric chain hoist model CPE is designed to lift and lower loads up to the rated capacity. The lifting capacity indicated on the hoist / trolley is the maximum safe working load which must not be exceeded.

Danger zones

- Do not lift or transport loads while personnel are in the danger zone.
- Do not allow personnel to pass under a suspended load (see Fig. 2)
- After lifting or tensioning, a load must not be left unattended for a longer period of time.

Attaching the trolley

- The operator must ensure that the trolley is attached

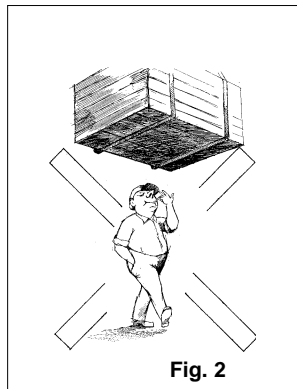

correctly and can be operated in a manner that does not expose himself or other personnel to danger by the hoist, trolley, chain(s) or the load.

Temperature range

- The hoist / trolley can be operated in ambient temperatures between -10°C und $+50^{\circ}\text{C}$. Consult the manufacturer in case of extreme working conditions.

Regulations

- The accident prevention act and/or safety regulations of the respective country for using manual and electric hoists must be strictly adhered to. In Germany these are VBG 8, VBG 9, VBG 9a, ZH 1/25, ZH 1/27, and VDE 0100 resp. VDE 0130.

Maintenance / Repair

- In order to ensure correct operation, not only the operating instructions, but also the conditions for inspection and maintenance must be complied with. If defects are found stop using the hoist / trolley immediately.

Attention: Before starting work on electrical components switch OFF the main current switch and secure it against unintentionally being switched back on.

2.2 Incorrect operation

- Do not exceed the rated capacity of the trolley.
- Do not use the trolley for the transportation of people (Fig. 3)
- Welding on the trolley is strictly forbidden (Fig. 5).
- Avoid side pull, i.e. side load on either traverse or sideplate (Fig. 4).
- Do not throw the trolley down. Always place it properly on the ground.

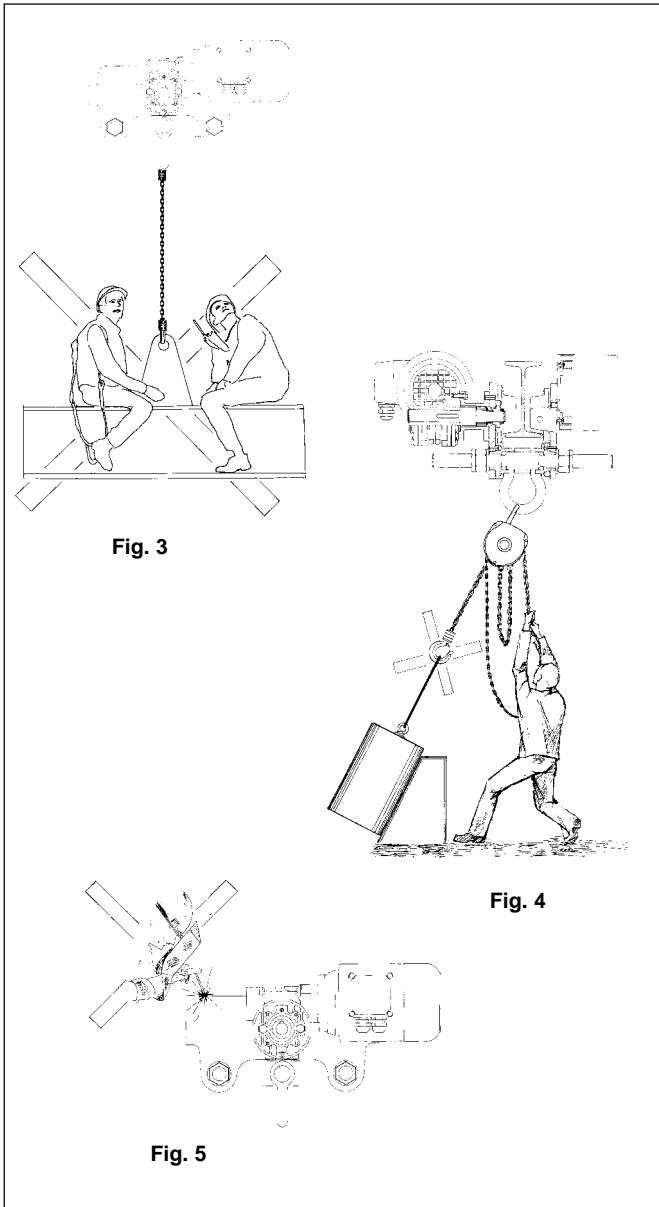

2.3 Initial operation

Inspection before initial operation

Each trolley must be inspected prior to initial operation by a competent person and all irregularities rectified. The inspection is visual and functional and shall establish that the unit is safe and has not been damaged by incorrect transport or storage. In particular check that the roll-pins are correctly fitted (see page 4, fig. 6) Inspections should be made by a representative of the manufacturer or the supplier although the company can assign its own suitably trained personnel. Inspections are instigated by the user.

• Inspection before starting work

Before starting work, inspect the electric trolley and all load bearing constructions visual every time for obvious defects. Furthermore, check that the trolley, hoist and load are correctly seated. The selection and calculation of a suitable suspension point is the responsibility of the user.

• Inspection of traverse

Check the structure for correct assembly and visually check for external defects, deformations, superficial cracks, wear or signs of corrosion.

• Check trolley width adjustment

Check that the clearance between the trolley wheel flange and the beam outer edge is equal on both sides and within the tolerances (see 2.5). Enlarging the clearances, e.g. to enable the trolley to negotiate tighter curves, is forbidden.

2.4 Electrical connections

Attention:

Work on electrical components and systems may only be carried out by trained craftsmen. All local regulations are to be adhered to e.g. DIN 7100 / VDE 0100 and DIN 57133 / VDE 0113.

Preparation

- Before beginning work on electrical components the mains current switch must be switched **OFF** and secured against unintentionally being switched on.
- Before connection, ensure that the electrical data on the nameplate matches the local supply specifications.
- The mains supply cable must be an insulated cable with four flexible leads. The ground (earth) lead must be longer than the live leads. Use sleeved on all the lead ends.
- The length of the pendant control cable is determined by working conditions. Attach the support wire in a manner that the pendant control cable hangs load-free.
- Wiring and terminal connecting diagrams are shown on the inside of the terminal box cover.

2.5 Function / operation

• Assembly instruction

The trolleys are supplied pre-assembled for beam widths A or B (see technical data on page 1). This is shown on the nameplate. Before installation, ensure that the trolley width is correct for the intended carrying beam.

- 1.) Unscrew the locking and securing nuts (see Fig. 6, page 4) and remove the sideplates from the traverses.
 - 2.) Measure the flange width "b" of the beam (see Fig. 6, page 4).
 3. Adjust the measurement "B" between the shoulders of the round nuts on the threaded traverses (see Fig. 6). Ensure that the 4 bores in the round nuts face towards the outside. Adjust the measurement "B" to equal the measurement "b" plus 4 mm. The measurement "A" must be 2 mm and the suspension traverse must be centred between the shoulders of the round nuts.
 4. Replace one sideplate ensuring that the roll pins in the sideplate engage into the bores in the round nuts. To achieve this it may be necessary to rotate the round nuts slightly.
 5. Replace the washers and tighten the securing nuts. Screw on the locknuts fingertight and tighten a further 1/4 to 1/2 turn.
- Attention:** The locknuts must always be fitted.
6. Loosely replace second sideplate on the traverse. The washers, nuts and locknuts can be fitted loosely.
 7. Raise the complete pre-assembled trolley to the carrying beam.

8.) Engage the second sideplate ensuring that the roll pins in the sideplates engage into the bores in the round nuts. To achieve this it may be necessary to rotate the round nuts slightly.

9.) Tighten the securing nuts on the second sideplate. Tighten the locknuts fingertight and then a further 1/4 to 1/2 turn.

Attention: The locknuts must always be fitted.

10.) By traversing the trolley check following:

- that a clearance of 2 mm on each side between the trolley wheel flanges and beam edge is maintained.
- the centre traverse is centred below the beam.
- that all locknuts are fitted and secured.

2.6 Traversing the trolley

The trolley is traversed by pressing the appropriate button on the pendant control. If the trolley malfunctions it must be taken out of operation immediately.

2.7 Inspection / service

• Regular inspections

To ensure that the trolley remains in safe working condition it is to be subjected to regular inspections by a competent person. Inspections are to be annual unless adverse working conditions dictate shorter periods. The components of the trolley are to be inspected for damage, wear, corrosion or other irregularities and all safety devices are to be checked for completeness and effectiveness. To check for worn parts it may be necessary to disassemble the trolley. Repairs may only be carried out by a specialist workshop that uses original Yale spare parts. Inspections are instigated by the user.

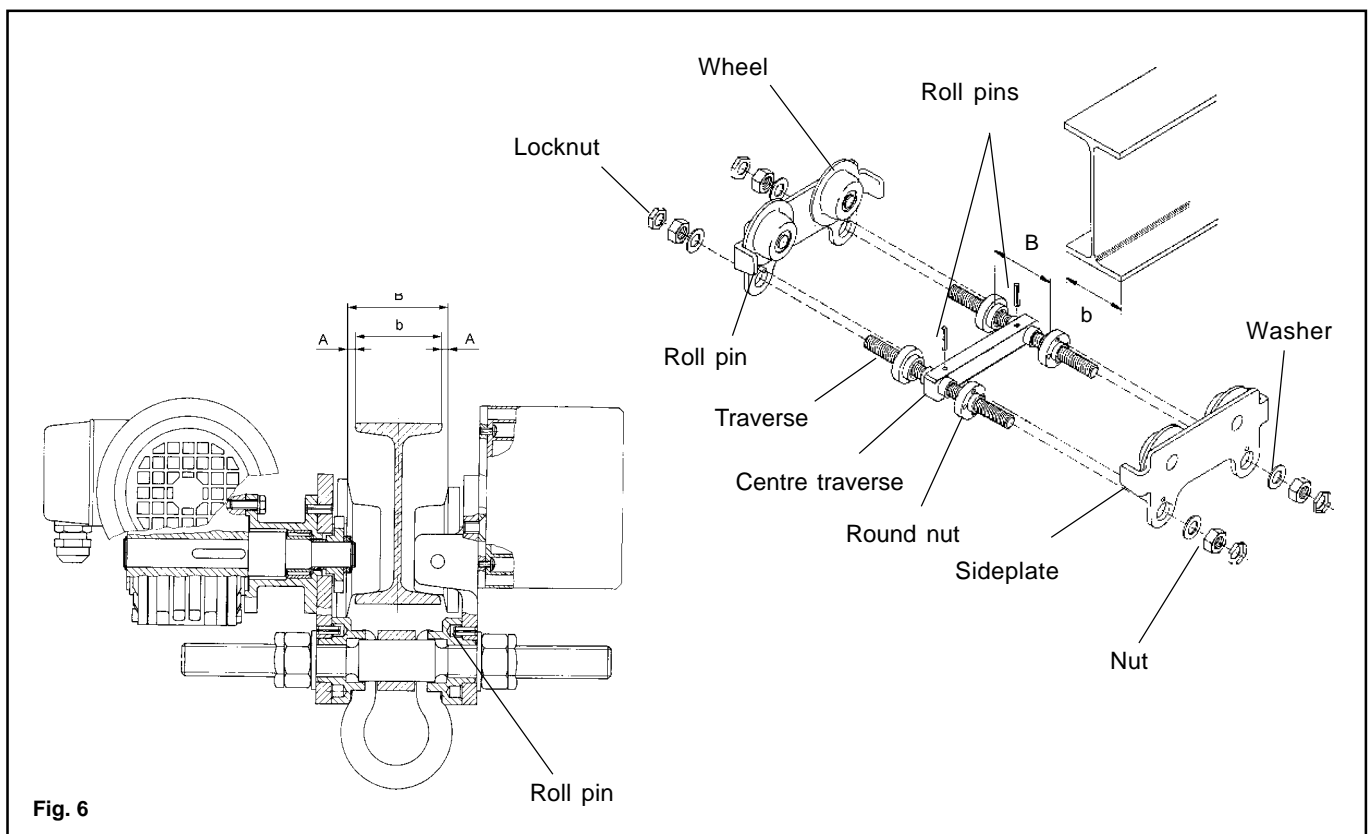
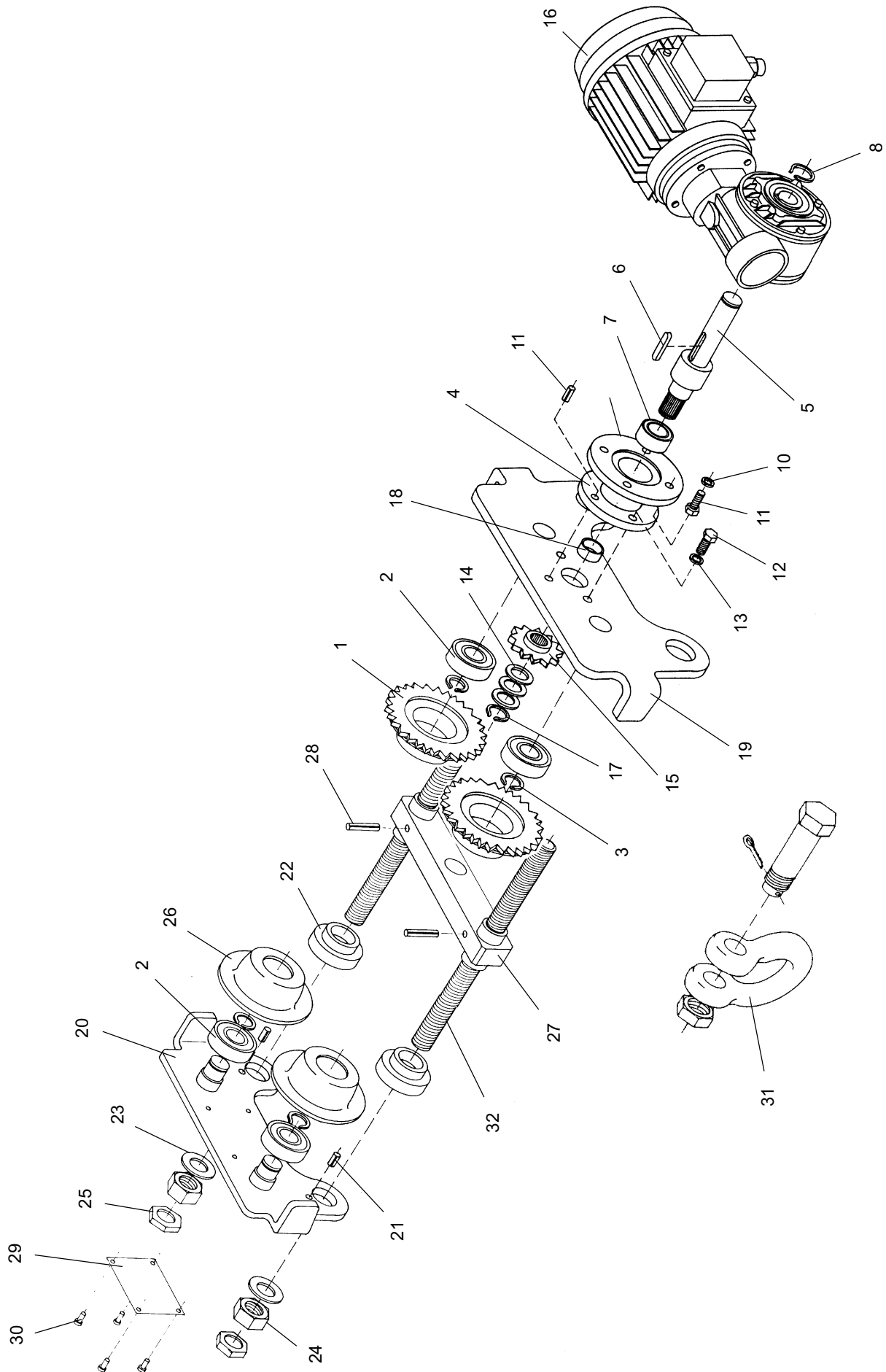

Fig. 6

Yale Electric Trolley VTE/F-U



Yale Electric Trolley VTE/F-U



* 3000 kg and 5000 kg only

Item No.	Description	Qty.	Yale Part No.				
			1000 kg	2000 kg	3000 kg	5000 kg	
1	Geared trolley wheel	2	00508211	00508212	00508213	00508214	
2	Ball bearing	4/8*	09151074	09151011	09151046	09151079	
3	Snap ring	4	09129029	09129025	09129002	09129003	
4	Flange	1	00719601	00719601	00719371	00719371	
5	Drive shaft	1	00719623	00719623	00719372	00719372	
6	Fitting key	1	09131071	09131071	09131072	09131072	
7	Needle bearing	1	09153077	09153077	09153077	09153077	
8	Snap ring	1	09129028	09129028	09129016	09129016	
9	Hex. screw	4	09101170	09101170	09101170	09101170	
10	Lockwasher	4	09122003	09122003	09122003	09122003	
11	Roll pin	1	09134057	09134057	09134054	09134080	
12	Hex. screw	2	09101013	09101013	09101014	09101014	
13	Lockwasher	2	09122004	09122004	09122004	09122004	
14	Spacer	7	09121215	09121215	09121215	09121215	
15	Pinion	1	00719622	00719622	00719373	00719373	
16	Drive unit	1	00719624	00719624	-	-	
	- single speed 18 m/min	1	00719763	00719763	-	-	
	- dual speed 18/4,5 m/min	1	00710005	00710005	00710007	00710007	
	- single speed 11 m/min	1	00710006	00710006	00710008	00710008	
	- dual speed 11/2,8 m/min	1	09123038	09123038	09123038	09123038	
17	Snap ring	1	00719870	00719870	00719870	00719870	
18	Bushing	1	00559096	00559142	00559152	00559165	
19	Sideplate (Drive side)	1	00559089	00559140	00559154	00559167	
20	Sideplate	1	09134055	09134057	09134054	09134120	
21	Roll pin	4	00559090	00559146	00559157	00559168	
22	Round nut	4	09121021	09121146	09121016	09121213	
23	Washer	4	09115089	09115803	09115090	09115156	
24	Hex. nut	4	09115152	09115153	09115154	09115155	
25	Locking nut	4	00508207	00508208	00508209	00508210	
26	Trolley wheel	2	00719619	00719618	00719938	00719958	
27	Centre traverse	1	09134001	09134084	09134003	09134002	
28	Roll pin	2	00719679	00719679	00719679	00719679	
29	Identity plate	1	09128004	09128004	09128004	09128004	
30	Grooved nail	4	42000063	42000063	42000064	42000065	
31	Shackle assy.	1	00559091	00559144	00559158	00559169	
32	Crossbar	2	00559092	00559145	00559159	00559170	
	- beam range A						
	- beam range B						



Yale Electric Trolley VTE/F-U

EC DECLARATION OF CONFORMITY

in accordance with Machinery Directive 98/37/EEC, Appendix II A

We,

Yale Industrial Products GmbH
D- 42549 Velbert, Am Lindenkamp 31

hereby declare that the design, construction and commercialized execution of the below mentioned machine complies with the essential health and safety requirements of the EC Machinery Directive. The validity of this declaration will cease in case of any modification or supplement not being agreed with us previously. Furthermore, validity of this declaration will cease in case that the machine will not be operated correctly and in accordance with the operating instructions and/or not be inspected regularly.

Machine description: Model VTE/F1-A-18/U, VTE/F1-B-18/U
Model VTE/F2-A-18/U, VTE/F2-B-18/U
Model VTE/F3-A-18/U, VTE/F3-B-18/U
Model VTE/F5-A-14/U, VTE/F5-B-14/U

Machine type: Electric trolley

Serial number: from manufacturing year 09/95
(Serial numbers for the individual capacities / models are registered in the production book with the remark CE-sign)

Relevant CE Directives: EC Machinery Directive 98/37/EEC

Transposed harmonised standards, in particular: EN 292, part 1 (safety of machines)
EN 292, part 2 (safety of machines)
EN 349 (safety of machines)

Transposed (either complete or in extracts) national standards and technical specifications, in particular: FEM 9.681 (Fahrmotoren)
FEM 9.755 (Betriebsdauer)
FEM 9.511 (Triebwerkseinstufung)
DIN 15018 (Krane)
DIN 15070 (Laufräder)
DIN 15085 (Laufräder)
VDE 0100 / Teil 726; VDE 0113 / EN 60204
VBG 8 (Winden, Hub- und Zuggeräte)
VBG 9 (Krane)
VBG 9.a (Lastaufnahmemittel)
ZH 1/27 (Prüfung von Kranen)
DIN 82101 (Schäkel)

Quality assurance: DIN/ISO 9001 resp. DIN/EN 29001, module H
acc. to EC Directive 90/683 EEC

Date / Manufacturer's

authorized signature:

24-04-2001

Identification of signee:

Quality Assurance Manager