

# tirak<sup>®</sup>

Electrically powered endless hoist  
for materials handling

## Original Operating Instructions



TIRAK<sup>®</sup>  
series  
X 300  
X 500  
X 700  
X 800  
X 1020

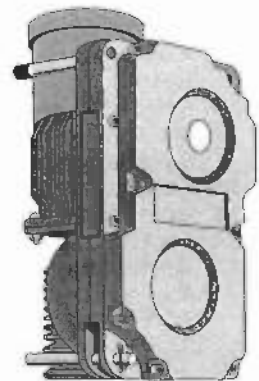
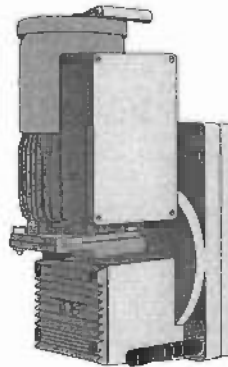

TIRAK<sup>®</sup>  
series  
T 1000

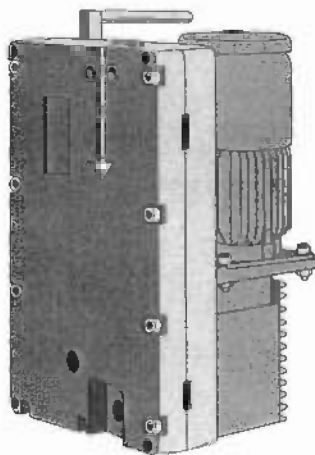

TIRAK<sup>®</sup>  
series  
X 3050

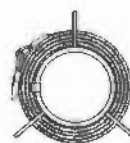

With TIRAK<sup>®</sup> wire ropes  
of different lengths  
on winders

This instruction manual must be available for the  
user at all times  
Additional copies may be obtained on request.

 **Tractel** Group

[www.tractel.com](http://www.tractel.com)

## Contents

	Page		Page
Information for this manual	2	5. Operation	
Notes for manufacturers of installation with built-in TIRAK®	3	5.1 Checks before starting	17
Explanation of symbols used	3	5.2 Weekly check of wire rope and cable	17
1. Safety advice	4	5.3 Operation	
2. Exclusion of non intended use	5	5.3.1 Stop/EMERGENCY STOP	17
3. Machine description		5.3.2 Service operation	17
3.1 Purpose	5	5.4 Securing moving loads	18
3.2 Working principle	5	5.5 Manual operation	
3.3 Allowed TIRAK® wire rope for materials handling	5	5.5.1 Emergency descent	18
3.4 Noise emission	5	5.5.2 Manual lifting	18
3.5 Main components and operating controls	6	6. Troubleshooting	18/19/20
3.6 Technical data	7	7. Out of Operation	
3.7 Increasing the capacity	7	7.1 Temporary stoppage	20
3.8 Anchoring examples	8	7.2 End of operation	20
3.9 Safety devices		8. Maintenance/Checks/Repair	
3.9.1 Primary brake	8	8.1 Maintenance	
3.9.2 Emergency stop	8	8.1.1 Hoist	21
3.9.3 Phase control relay	8	8.1.2 Wire ropes	21
3.9.4 Load limiting device	8/9	8.1.3 Motor, brake, and gear box	21
3.9.5 Manual operation		8.2 Checks	
3.9.5.1 Emergency descent	9	8.2.1 Essential checks	22
3.9.5.2 Manual lifting	9	8.2.2 Safety inspection	23
3.10 Residual risks	10	8.3 Repair	23
4. Setting up		9. Spare Parts	23
4.1 Required equipment	10	9.1 Hoist	23
4.2 Anchoring the TIRAK® hoist		9.2 Motor and brake	23
4.2.1 Anchoring devices and dimensions	10/11	9.3 Electrical control	23
4.2.2 Anchoring of the TIRAK® hoist	12/13	9.4 Nameplates and labels	23
4.3 Wire rope exit			
4.3.1 Slack wire rope	13		
4.3.2 Use of wire rope winders	13		
4.4 Electric connections	14		
4.5 Electric controls	15		
4.6 Wire rope installation			
4.6.1 Preparing the wire ropes	15		
4.6.2 Wire rope installation	16		

### Information for this Operating and Maintenance Manual

**Date of edition**

1. Edition: May 2000

**Copyright**

The copyright of these assembly and operating instructions shall remain with the manufacturer.

**Address of the manufacturer:**

GREIFZUG Hebezeugbau GmbH

Scheidt bachstraße 19-21

51469 Bergisch Gladbach

Germany

Telefon: +49 / 22 02 / 10 04-0

Telefax: +49 / 22 02 / 10 04-50 or -70

For addresses of other TRACTEL Group Companies see page 28.

## Notes for manufacturers of an installation with built-in TIRAK®



### Important!

The manufacturer of an installation for lifting/pulling/driving loads in which a TIRAK® hoist is built in must indicate all instructions for the safe use of this installation at the corresponding points of the instructions which must be prepared for the installation by the manufacturer.

Merely enclosing these instructions does not satisfy the requirements of the EC Machinery Directive or the applicable standards!

## Explanation of symbols used

<u>Safety advice</u>			
Symbol	Code word	Meaning	Possible consequences of non-compliance
	DANGER	IMMEDIATE or possibly imminent danger:	Fatal or serious injuries!
	DANGER	IMMEDIATE or possibly imminent danger through dangerous voltage:	Fatal or serious injuries!
	CAUTION	Possibly dangerous situation:	Injuries to persons or damage to property.
<u>Altre avvertenze</u>			
	Attention	Possibly dangerous situation:	Damage to appliance, or its surroundings.
	Important	Useful tips for optimum working:	None
<u>Directions</u>			
	(without code word)	Instruction to operation/ documentation in writing.	

# 1. Safety advice



Follow all instructions and safety regulations contained in this manual to avoid injuries.

- a) **DO NOT** overload the TIRAK® hoist.
- b) **DO NOT** stand below a suspended load.
- c) TIRAK® hoists must only be used for lifting, pulling, lowering, and moving back-and-fro of loads<sup>1)</sup>. Use for other purposes is not allowed.
- d) TIRAK® hoists with standard electric equipment must not be used in a potentially explosive atmosphere<sup>2)</sup>.
- e) Anchoring, maintenance, and/or the operation of TIRAK® hoists must only be done by persons, who are familiar with it. Employees must have received the instruction to anchor, maintain, and/or operate the hoist by their employer.
- f) The operator has to know and to follow all relevant local safety regulations, and maintenance recommendations, as well as this operating instruction, and the operator must have been instructed.
- g) The operator must not start any movement of the load until he has checked that the hoist and the load are properly anchored, and that no person is stood in the danger zone below any suspended load, or until he has got a starting signal from the slinger.
- h) The operator must watch the load during all movement operations of the hoist. If the operator is unable to watch the complete working area, the danger zone must be cordoned off, or a second person must be positioned to enable the complete working area to be watched and have adequate means of communication with the hoist operator during the whole operation.
- i) The TIRAK® hoist has to be anchored so that the wire rope under load is vertically entering the hoist.
- k) Use only the recommended TIRAK® rope in good condition. Use only normally commercially available multi-purpose grease for the lubrication of the rope. Do not use lubricants containing disulphide (e.g. Molycote®).
- l) When using a rope other than the recommended TIRAK® rope the warranty entitlement given by GREIFZUG Hebezeugbau GmbH or other company of the TRACTEL Group shall not apply.
- m) Before starting the assembly check all parts for completeness and error-free quality.
- n) Only anchor the TIRAK® hoist at the points provided for this purpose (connection rods, anchor points, or load pins).
- o) When using self-securing nuts please observe the following:
  - the screw must protrude from the nut with at least half its thread diameter;
  - do not re-use nuts if they can be unscrewed by hand!
- p) Do not use the wire rope to fix the load, and do not pull it over sharp edges.
- q) Do not fix any load to the free wire rope end, which exits from the winch at the opposite side to the wire rope under load.  
Exception: Use of a TIRAK® hoist of the type series T 1000 in to-and-fro travel.
- r) Never use a rope which is too short for the job you are doing. When the load or machine is at its lowest point, a minimum length of 1 metre of wire rope should be below the rope exit of the TIRAK®.
- s) The ferrule of the wire rope hook must not reach the TIRAK®-casing during lifting/pulling the load.  
Exception: A limit switch for lifting limitation is attached to the TIRAK® hoist (see accessories on page 25).
- t) The electrical connection of the TIRAK® as well as of electrical accessories must be carried out in accordance with EN 60204-1.
- u) Checks and repairs to the electrical system must only be carried out by qualified electricians.
- v) Other checks and repairs must only be carried out by GREIFZUG Hebezeugbau GmbH, an other company of the TRACTEL Group or by a hoist workshop.
- w) GREIFZUG Hebezeugbau GmbH or other company of the TRACTEL Group shall assume no liability for damages resulting from conversions or alterations to the devices supplied by itself or as a result of the use of non-original parts.

1) TIRAK®-Hoists for man riding on request.

2) TIRAK®-Hoists can be supplied for these applications on request.

## 2. Exclusion of non-intended use

Use of standard TIRAK® hoists and other equipment for materials handling under the following conditions is **prohibited**:

- at temperatures **below -10 °C or above +50 °C**,  
for **X 1030 to 2050 P series below -15 °C or above +80 °C**  
(for advice regarding gearbox oils for lower/higher temperatures see chapter 8.3);
- in potentially explosive atmosphere.

Machines for these conditions can be supplied on request.

## 3. Machine description

### 3.1 Purpose

TIRAK® hoists of the series

**X 300 , X 500 , X 700 , X 800 ,  
T 1020, X 1000, X 3050**

are portable, electric driven hoists for

**lifting, lowering, pulling, and  
movement of loads**

by means of a TIRAK® wire rope prescribed by the manufacturer.

This wire rope is mandatory for the safe and trouble-free working with TIRAK® hoists.

### 3.3 Allowed TIRAK® wire rope for materials handling

for TIRAK®-series	Wire rope-Ø
X 300 X 500 X 700 X 800 T 1000	8 mm
X 1020	9 mm
X 3050	14 mm

**Identification:** one red strand.

**Diameter indication** on the ferrule:

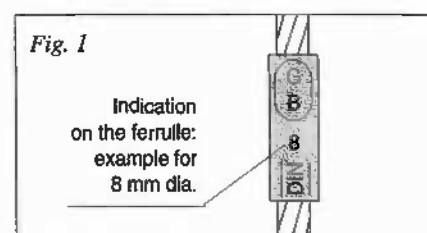

### 3.2 Working principle

Provided that TIRAK® hoists are aligned in the direction of pull, they will work in any position and in any direction.

For either lifting or lowering there is one corresponding push button. The wire rope is driven through the winch with constantly equal safety, and the length of wire rope i. e. the possible pulling length, is practically unlimited.

TIRAK® hoists with a capacity of 1000 kg or more have an integrated load limiting device.

TIRAK® hoists of T 1000 series can pull in both directions.

### 3.4 Noise emission

TIRAK® series	(Distance 1 m)
X 300: .....	max. 72 dB(A)
X 500/700/800/1020, T 1000: .....	max. 70 dB(A)
X 3050 .....	max. 78,5 dB(A)

### 3.5 Main components and operating controls

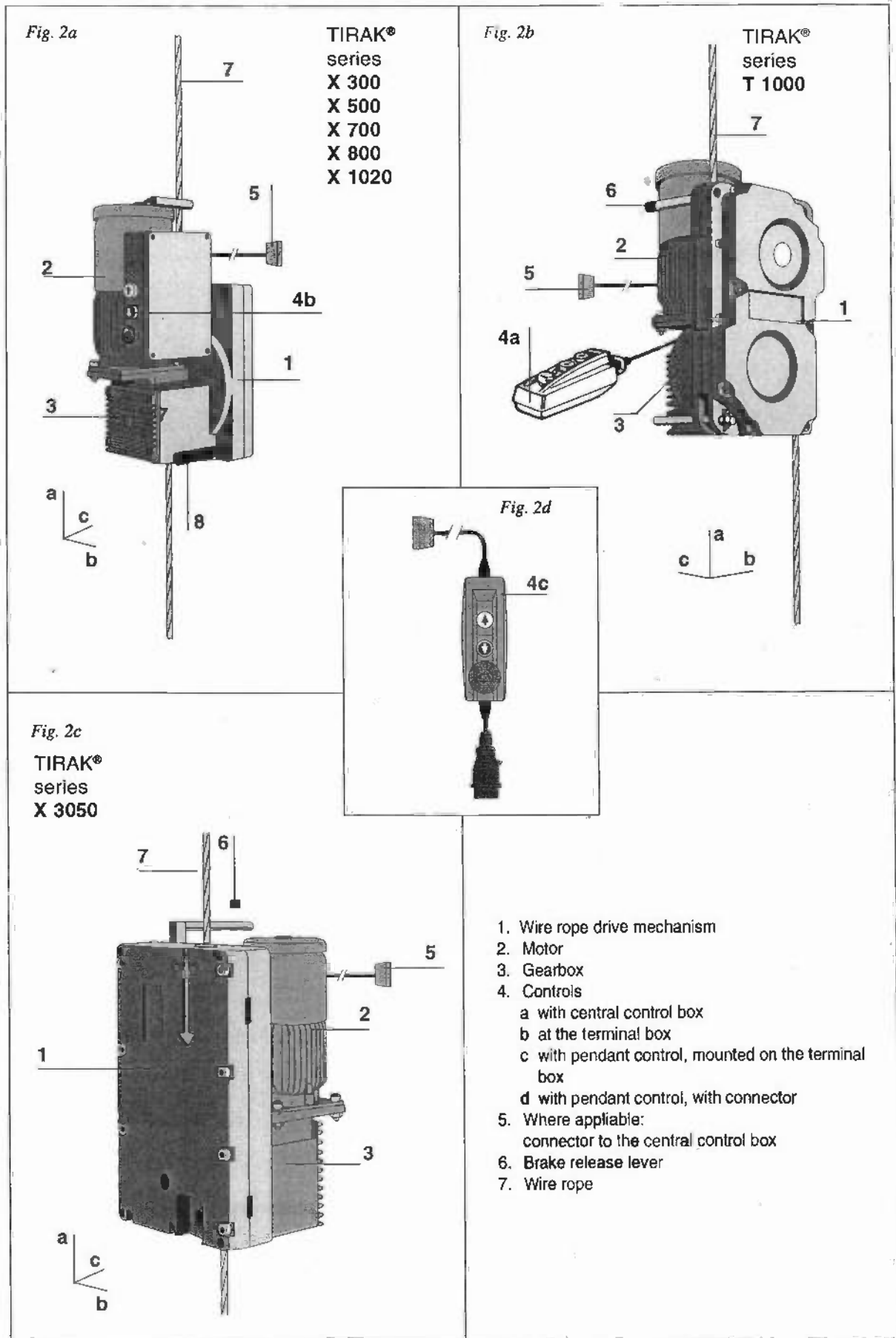

### 3.6 Technical Data

Design according to DIN 15 020, transmission group 1 B<sub>m</sub> resp. 1 C<sub>m</sub>.  
Technical modifications reserved.

Hoist	Capacity	Rope speed	Type of drive	Output	Rated current	TIRAK® rope Ø	Dead weight approx.	Dimensions		
								a	b	c
<b>TIRAK®-Model</b>	kg <sup>2)</sup>	m/min	- <sup>3)</sup>	kW	A	mm	kg <sup>4)</sup>	mm	mm	mm
X 300	300	9	D	0,5	1,6	8	27	437	262	265
X 302		18	D	0,9	2,6	8	27	437	262	265
X 301		9	W	0,45	4,5	8	29	476	257	245
X 500	500	9	D	0,9	2,8	8	40	489	297	265
X 502		18	D	1,8	5,0	8	43	504	297	265
X 503		9/18	D	0,9/1,8	2,8/5,1	8	47	504	297	285
X 501		9	W	0,9	6,5	8	49	556	297	256
X 700	700	9	D	1,5	3,9	8	45	525	297	265
X 800	800	9	D	1,6	4,5	8	45	525	297	265
X 805		4,5/9	D	0,8/1,6	3/4,2	8	50	563	304	285
X 806		4,5/18	D	0,8/3,2	3,6/9	8	71	603	328	315
X 803		9/18	D	1,75/3,5	4/8	8	49	550	297	285
T 1000	980	9	D	1,9	4,6	8	71	580	336	311
T 1005	(1000 <sup>5)</sup> )	4,5/9	D	0,9/1,9	3,6/4,6	8	84	642	355	318
T 1006		4,5/18	D	0,9/3,8	4,0/9,7	8	94	679	386	348
T 1003		9/18	D	1,9/3,8	5,5/9,5	8	85	642	355	348
X 1020	980	9	D	1,9	4,6	9	45	525	297	265
X 1025	(1000 <sup>5)</sup> )	4,5/9	D	0,9/1,9	3,5/4,8	9	55	563	307	285
X 1026		4,5/18	D	0,9/3,8	4/9,6	9	71	605	332	315
X 1023		9/18	D	1,9/3,8	4,5/9,5	9	56	563	307	315
X 3050	3000 <sup>5)</sup>	6	D	3,8	9,9	14	105	669	400	372
X 3052		12 <sup>6)</sup>	D	7,5	17	14	117	681	403	372
X 3053		6/12 <sup>6)</sup>	D	3,8/7,5	9,9/19	14	156	786	428	442

Table 1

- 1) Hoist to 9 m/min = transmission group 1B<sub>m</sub>. Hoists over 9 m/min = transmission group 1C<sub>m</sub>.
- 2) If the capacity is not sufficient in direct pull, multiply it by reeving the rope according to the block and tackle principle.
- 3) D = 415 V three phase current; W = 110/220 V single phase current.
- 4) Weight without wire rope. 5) With load limiting device.
- 6) 60 % duty cycle at 12 m/min.

### 3.7 Increasing the capacity by reeving the wire rope

If the capacity of the TIRAK® hoist is not sufficient in direct lifting or pulling, it can be multiplied by reeving the wire rope according to the block and tackle principle.

But double capacity means half speed, triple capacity means 1/3 speed etc.



**Important for horizontal pull:**  
Do not confuse the **dead weight** of the load with the **effort required to pull it**: the TIRAK® has only to overcome the friction coefficient.

**Attention!** A competent person must check –

- a) that the pulleys and the anchoring devices as well as all anchor points are of sufficient strength, and
- b) that the pulleys are of the correct diameter.

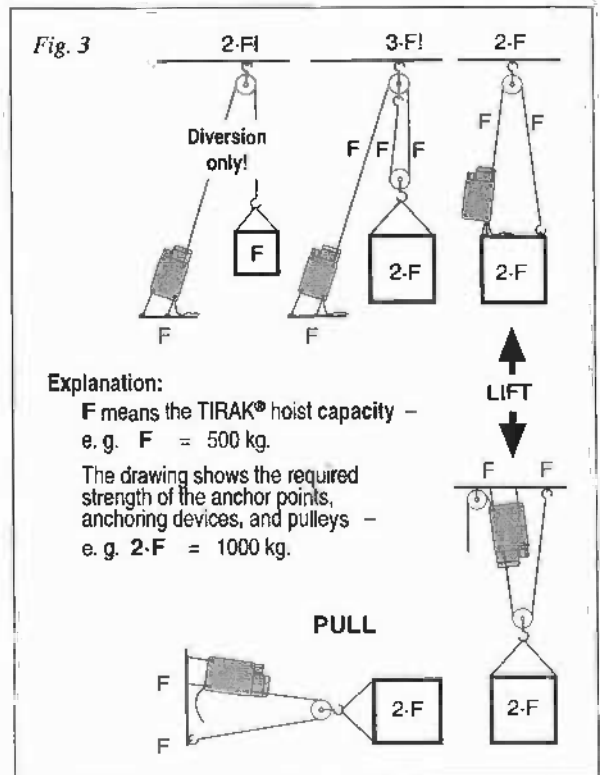

### 3.8 Anchoring examples for materials handling

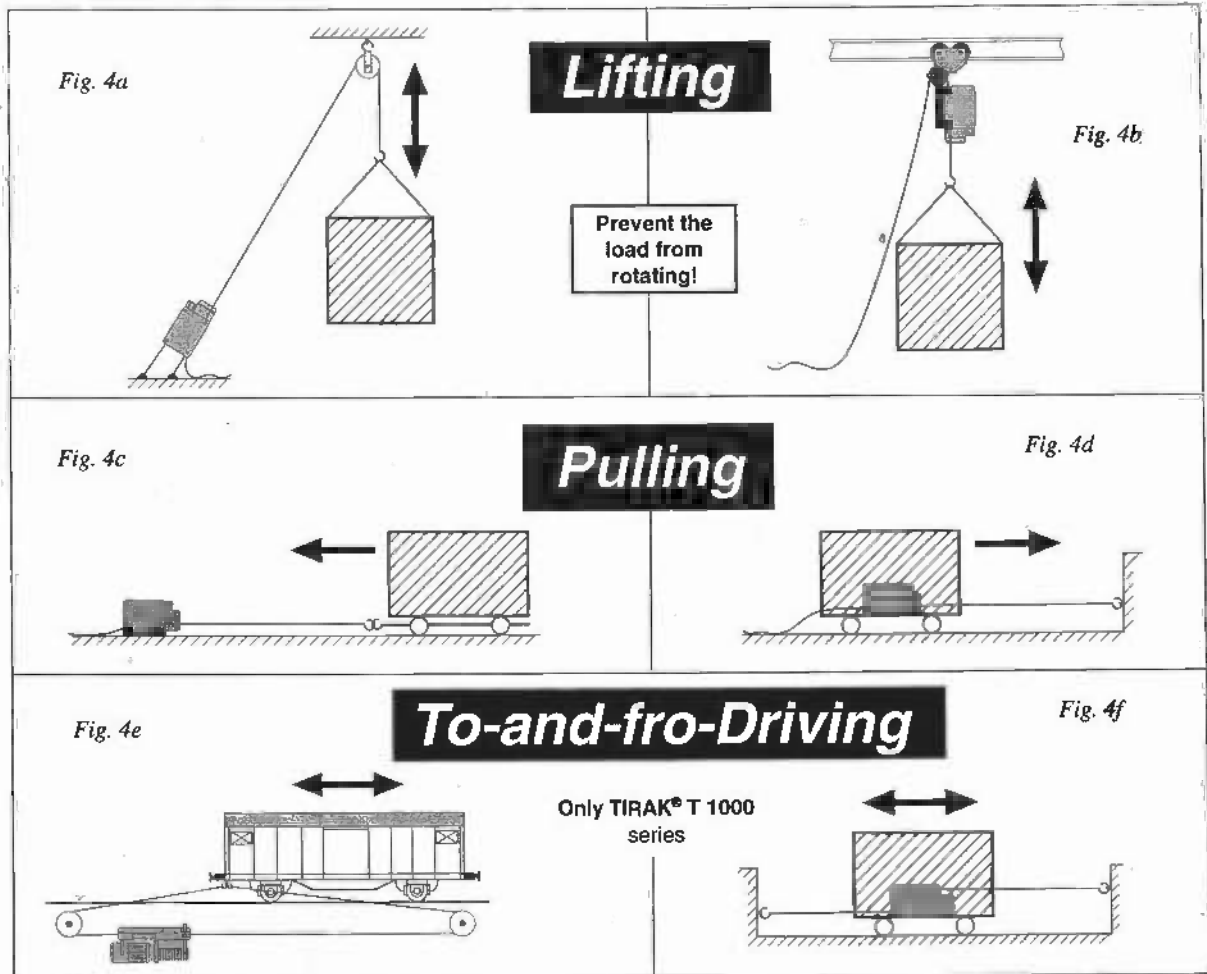

### 3.9 Safety devices

#### 3.9.1 Primary brake

Electromagnetic brake which closes automatically

- if the UP/Down-button is released
- in case of power supply failure.

#### 3.9.2 Emergency Stop

Pushing the red EMERGENCY STOP button in case of emergency completely switches off the hoist control. To start after clearing the problem, turn the EMERGENCY-STOP button clockwise until it releases.

#### 3.9.3 Phase control relay

In controls with 3-phase motors, the integrated phase control relay stops the operation if the phases are reversed. This prevents wrong coordination of the UP/DOWN-buttons which would prevent operation of the load limiting device.

**Correction:** turn the phase inverter of the plug by 180° (Fig. 6).

Fig. 5

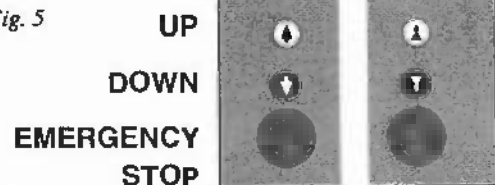
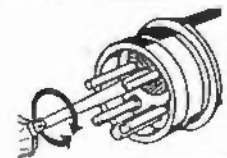

Fig. 6

Phase inverter  
in CE-plug



#### 3.9.4 Load limiting device

TIRAK®-Models with 1000 kg capacity or more are equipped with a load limiting device.

The load limiting device is set by the manufacturer in such a manner that it switches off the lifting movement at the latest when the load has reached 1.25 times the carrying capacity of the hoist.

##### 3.9.4.1 Electronic pulling force limiting device

Possible causes for switching off:

- overload or
- blocking of the load when lifting/pulling.



### Action following switching off:

Press DOWN button,

- until the load has settled and reduce the load until there is no longer any overload or
- until the load is free from the obstacle. **Remove the obstacle** before continuing to lift or pull.

### Function of the load limiting device

The electronic load limiting device reacts to the current consumption of the motor. The overload is detected during lifting/pulling.

### Reducing the switch off threshold value

Setting to a lower threshold value e.g. as a result of a lower carrying capacity of the components to which the hoist or diverter pulleys are anchored, can only be carried out by a qualified electrician or a hoist workshop (fig. 7):

### A Pre-Setting

#### A.1 Nominal current

Turn upper regulator to the right as far as the stop.

#### A.2 Start-bridging

Turn lower regulator to the right as far as the stop.

### B. Setting

(Example for TIRAK® X 1030)

#### B.1 Setting the overload

Attach **overload = rated load + 25 %**  
(e. g. 1250 kg)

During the lifting of the overload turn the **upper regulator** to the left until the hoist stops.

Lower overload until the rope is slack.

Again lift overload – the hoist must stop as soon as it comes under load.

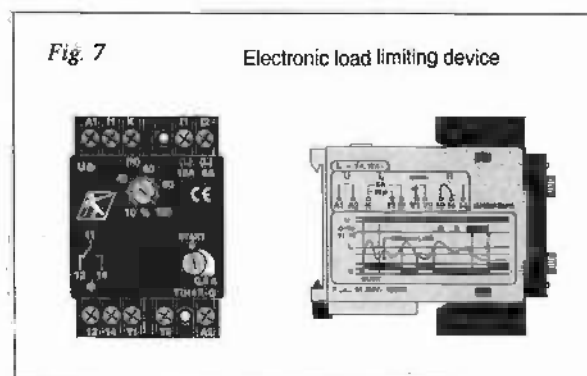

#### B.2 Setting the rated load

Attach **rated load** (e. g. 1000 kg) and lift the nominal load from ground.

Turn lower regulator to the left as far as the stop.

Press UP button – the hoist must stop immediately.

**Following each stopping of the hoist during this setting procedure, press the DOWN button shortly so that the upward travel is again possible.**

Step by step

- turn the **lower regulator** slightly to the right,
  - then press UP button,
- until lifting of the **suspended nominal load** is possible.



**Important note for TIRAK® with 2 speeds (pole changing motor):**

The control system contains 2 load limiting devices, the setting must be carried out for **both speeds**.

### 3.9.4.2 Mechanical load limiting device

The load limiting device is installed in the rope drive and switches off the UPWARD travel in the event of overload.

### Possible causes of switching off:

- overload or
- blocking of the load when lifting/pulling.

### Action following switching off:

Press DOWN button,

- until the load has settled and reduce the load until there is no longer any overload or
- until the load is free from the obstacle; **remove obstacle** before continuing to lift or pull.

### 3.9.5 Manual operation

Details in chapter 5.5 on page 18

#### 3.9.5.1 Emergency Descent

In case of power failure you can manually open the brake with lever (1) (Fig. 8).

#### 3.9.5.2 Manual lifting

With the **brake opened** the load can be lifted with the hand wheel (2) placed on the motor shaft (Fig. 8).

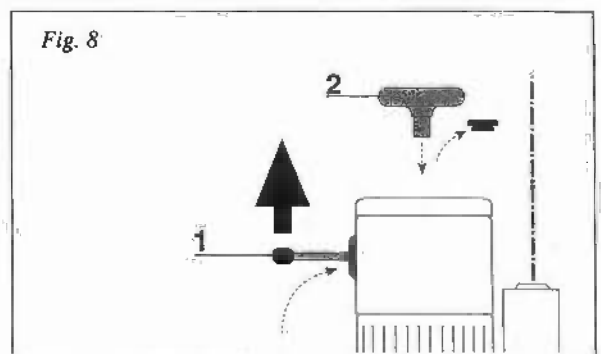

### 3.10 Residual risks



#### CAUTION!

The following risks are not constructively covered for the TIRAK® hoist :

On TIRAK® hoists without limit switch (standard version):

- a) **Damage to the rope** when the rope hook is pulled as far as the TIRAK® housing. Consequently **observe rope hook during lifting/pulling** so as to be able to stop in time.
- b) **Running out of the slack wire rope end**. Consequently
  - always ensure a **sufficiently long rope**;
  - **watch rope end during lowering/slackening** so as to be able to stop in good time.

On TIRAK® hoists with load limiting device:

- c) The **load limiting device** is set to the maximum carrying capacity of the respective hoist. Should a lower value be necessary e.g. due to a lower carrying capacity of components to which the hoist or diverter pulleys are anchored:
  - have **electronic load limiting device** set by a qualified person (see section 3.9.4);
  - have **mechanical load limiting device** set by the manufacturer.
- d) The **electronic load limiting device** only detects an overload during lifting/pulling. Therefore particular care should be exercised when a load carrying device (material container or similar) is loaded when suspended or being lowered.

## 4. Setting up

### 4.1 Required equipment

- a) TIRAK® of correct capacity, speed and voltage. Machines with a **capacity of 1000 kg or more** must have a built-in load limiting device.
- b) TIRAK® wire rope with correct diameter and of sufficient length. Grease to lubricate the rope
- c) Electric supply cable of correct type and required length, with correct number of wires and cross sectional area.
- d) Anchoring devices for fixing the load i.e. slings, belts or similar of sufficient strength.
- e) Pulleys for diverting or reeving the wire rope of sufficient strength and diameter.

Check condition of all components.

Table 3

### 4.2 Anchoring the TIRAK®-Hoist

#### 4.2.1 Anchoring devices and dimensions

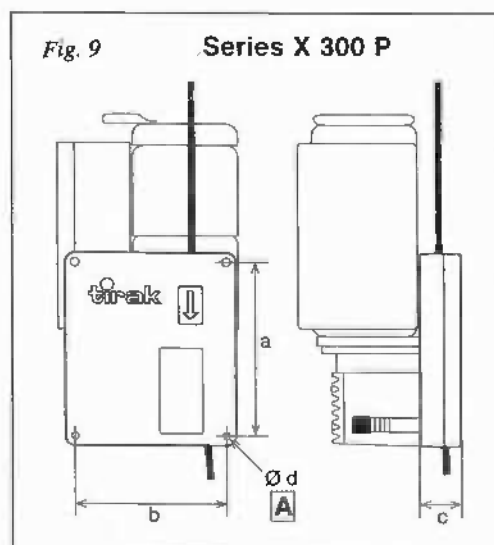

Dimension	Dimensions [mm] for TIRAK® series			
	X 300	X 500 / 700 / 800 X 1020	T 1000	X 3050
a	255	300	449	570
b	220	267	250	360
c	60	60	56	117
Ø d	10,5	10,5	-	16,1
e	-	35	-	45
e <sub>1</sub>	-	-	-	35
f	-	67	-	132
g	-	26	28	40
h	-	19	14	27
h <sub>1</sub>	-	-	-	70
Ø i	-	16,5	16,5	30,1
k	112	100	-	-
l	40	40	-	70
m	12	12	-	-
n	98	98	-	-
o	32	32	-	-
p	26	26	-	-
Ø q	13	13	-	-

### Anchoring devices

- Series X 300/500/700/800 and X 1020 when screwing the housing to the points (A):  
M10x... screws, at least grade 8.8 with self-locking nuts;
- series X 300/500/700/800 and X 1020 when anchoring by means of the adapter (Fig. 11):  
M12x... screws, at least grade 8.8 with self-locking nuts;
- Series X 500/700/800/1020 P when screwing the housing to point (B):  
M16x... screws, at least grade 8.8 with self-locking nuts;
- Series T 1000 at points (C + D):  
M16x... screws, at least grade 8.8 with self-locking nuts;
- Series X 3050 when screwing the housing to the points (A):  
M16x... screws, at least grade 8.8 with self-locking nuts;
- Series X 3050 when screwing to point (B):  
M30x... screws, at least grade 8.8 with self-locking nuts;

Instead of the screws, bolts or similar with at least the same strength can be used.

Fig. 10

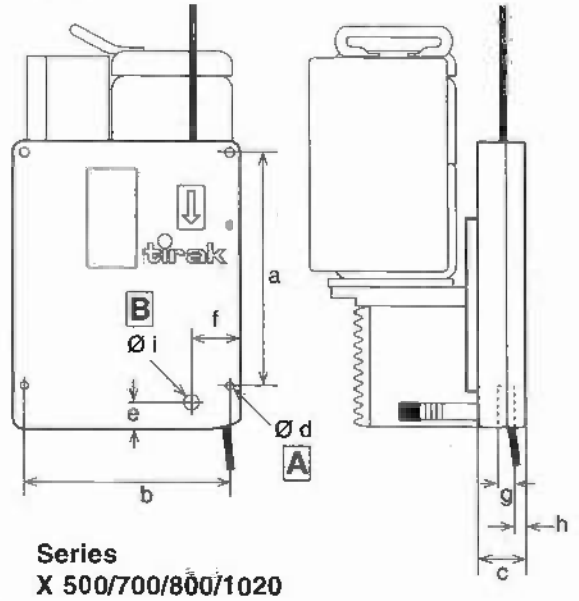

Series X 500/700/800/1020

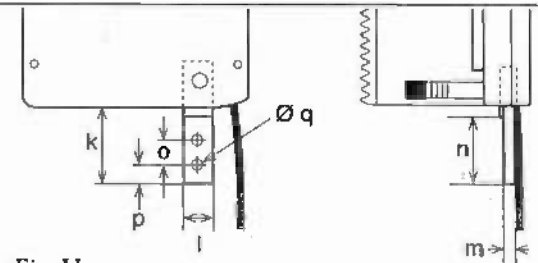
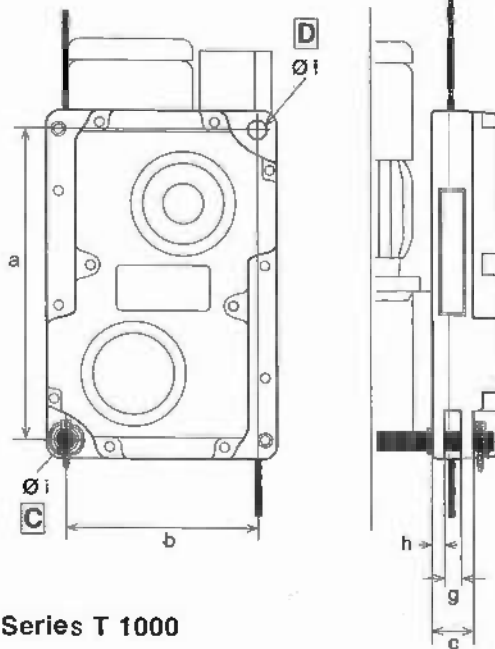

Fig. 11

Adapter (optional) for Series X 300/500/700/800/1020

Fig. 12



Series T 1000

Fig. 13

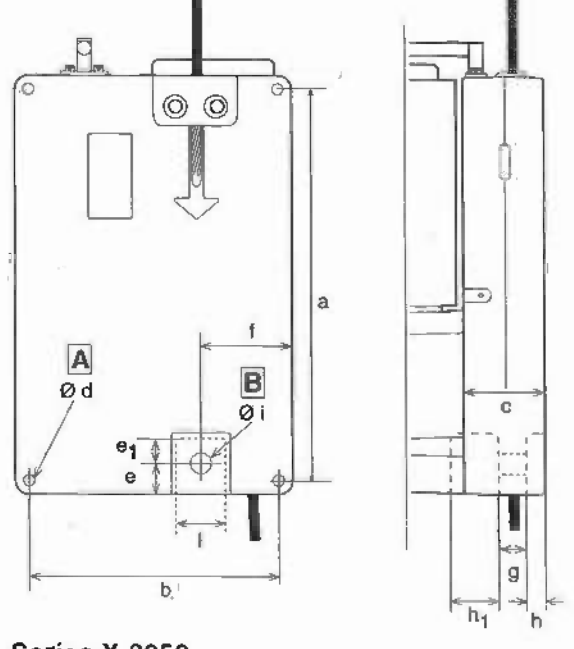

Series X 3050

## 4.2.2 Anchoring the TIRAK® hoist



### Attention:

ALWAYS anchor the TIRAK® hoist in such way that the wire rope enters the hoist perpendicularly, when under load (Fig. 14)

### A) TIRAK®-series X 300 / 500 / 700 / 800 / 1020 (Fig. 14)

- Anchor TIRAK® with the adapter at point (B), or
- anchor the TIRAK® hoist at least at two of the four anchoring points (A);  
allowed:  $A_1 \leftrightarrow A_2$ ,  $A_2 \leftrightarrow A_3$ ,  $A_3 \leftrightarrow A_4$



### Attention!

NOT allowed: anchoring only at points  $A_1 \leftrightarrow A_3$  or  $A_1 \leftrightarrow A_4$  or  $A_2 \leftrightarrow A_4$ .

Fig. 14

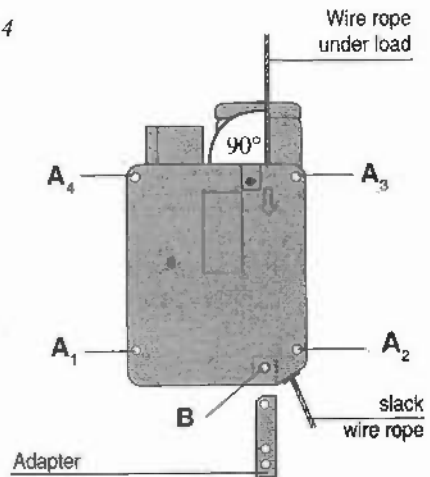

Series X 300/500/700/800/1020

### B) TIRAK®-series X 3050 (Fig. 15)

- Anchor TIRAK® hoist with bolt or shackle at point (B).



### Attention:

Support TIRAK®-hoist with additional adapters in the direction of pull.

- Or anchor the TIRAK® hoist at least at two of the four anchoring points ( $A_1$  to  $A_4$ );  
allowed:  $A_1 \leftrightarrow A_2$ ,  $A_2 \leftrightarrow A_3$ ,  $A_3 \leftrightarrow A_4$ ,



### Attention!

NOT allowed: anchoring only at points  $A_1 \leftrightarrow A_3$  or  $A_1 \leftrightarrow A_4$  or  $A_2 \leftrightarrow A_4$ .



### Attention:

It must be ensured by means of the mounting (C) that the force is distributed evenly over both anchor points.



### Important:

When planning the anchoring we recommend consultation with the manufacturer.

Fig. 15

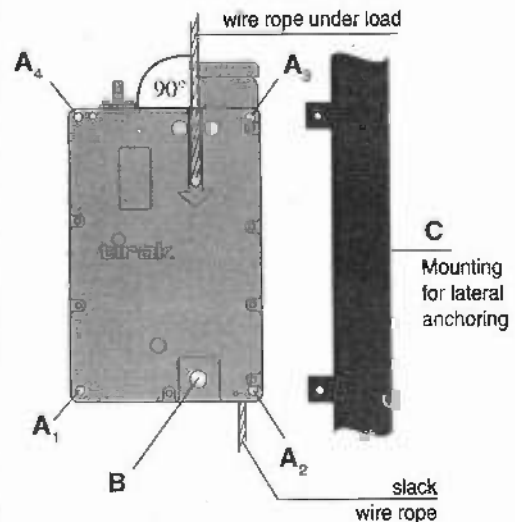

series X 3050

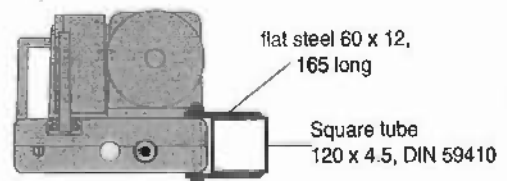

**C) TIRAK® series T 1000**  
(Fig. 16)

- If the load is to be pulled by the hook (C) in the direction of wire rope entry (A1), the TIRAK® must be anchored at point (B1).



**Attention:** On the screw connection (a) only tighten the securing nut to such an extent that approx. 1 mm play remains to the anchoring links (b) since otherwise these could be damaged (fig. 17).



**Attention:** If the load is to be pulled in the direction of wire rope entry (A2), the TIRAK® must be anchored at the point (B2) and the control must be changed by a qualified electrician so that the correct connection for UP-/DOWN-buttons is guaranteed.

- When pulling in both directions, you must anchor the TIRAK® at both points (B1 and B2). (Fig. 16).

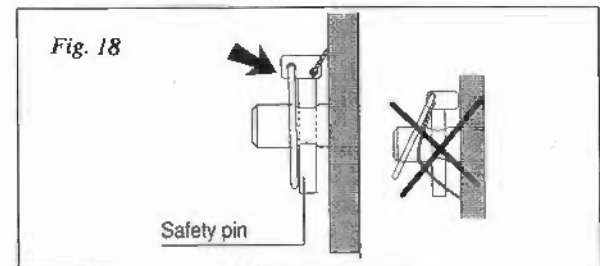
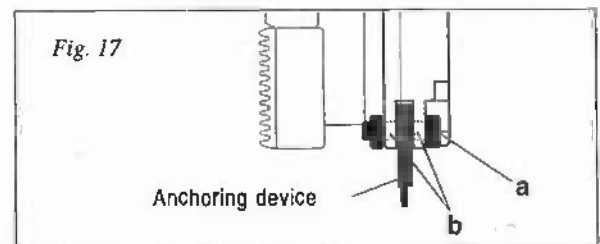
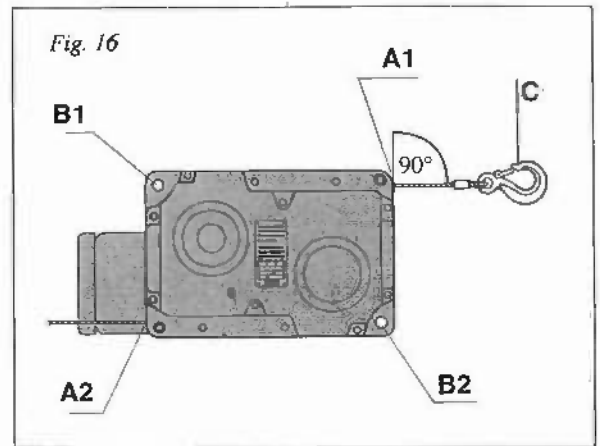

**D) All TIRAK® hoists!**



**Attention:** When using an anchor bolt with safety pin: Check the correct position of the safety pin according to Fig. 18.

**4.3 Wire rope exit**

**4.3.1 Slack wire rope**

Always ensure that the wire rope exit is not obstructed! Use a diverter pulley for the slack wire rope (Fig. 19) to prevent damage or use another wire rope leading system to prevent damage from rubbing over sharp edges.

Make sure that the slack wire rope

- is freely hanging down and able to untwist itself or
- is properly reeled to prevent the formation of loops/knots (Fig. 20)

**4.3.2 Use of wire rope winders**

The loose, unloaded end of the wire rope can also be stored on suitable wire rope winders (e.g. motor or spring wire rope drums).

When planning we recommend consulting the manufacturer of the TIRAK® hoists regarding design and arrangement of the wire rope winders.

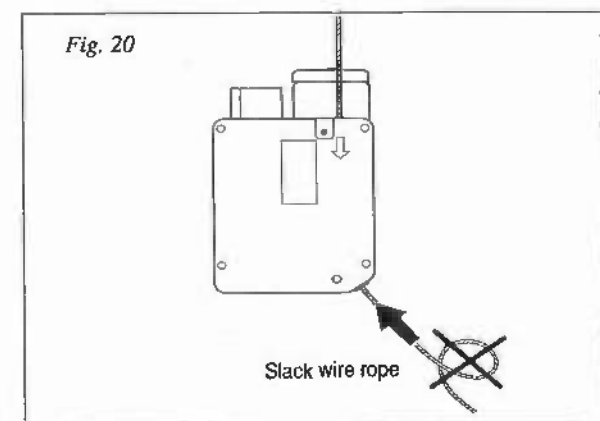
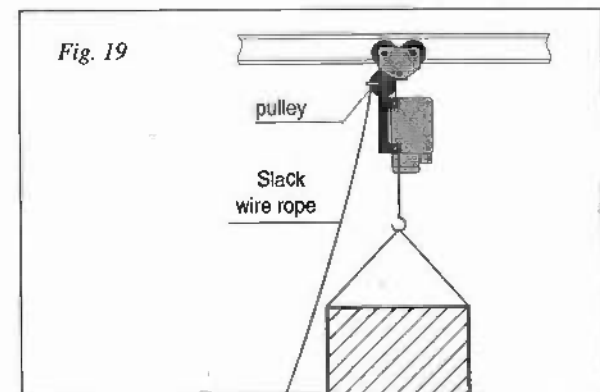

**A tip:** Mobile hoists with the TIRAK® are a very compact unit of hoist and wire rope winder. Details on page 26.

## 4.4 Electrical Connections



### DANGER!

The electrical connection for TIRAK® hoists must conform to EN 60204-1.

The lead must be protected by fuse by the customer.

Always pull the plug out before opening a central control!

- a) Ensure that the **mains voltage** is adequate for the **motor** of the TIRAK® –
- **Three phase:**  
400 V (3P + E + 0), 50 Hz,  
16 amp rated plug and socket
  - **Single phase:**  
230 V (2P + E), 50 Hz,  
16 amp rated plug and socket
- If in doubt ask.**

- b) To avoid power loss between power source and the TIRAK® always use power cables with **adequate cross sectional area**.  
See tables 4a and 4b.

#### Table 1a

indicates the reference letter of the TIRAK® model and the mains supply voltage.

**Maximum speed** must be used for TIRAK® with two speeds.

#### Table 1b

gives the **minimum cable cross section** based on the reference letter.

- c) Use only **heavy duty cables** with **incorporated strain relief**.

**Hanging cables** longer than 30 m should be fixed by means of a cable sleeve or cable clamp (Fig. 21).

- e) When using a **generator** its output must be at least **2.5 times greater** than the TIRAK® power consumption.



TIRAK® series	Max. wire rope speed m/min	1 TIRAK			2 TIRAK		
		3 phase		1 Ph	3 Phase		1 Ph
		400V	230V	230V~	400V	230V	230V~
X 300	9	A	B	C	A	D	E
	18	A	C	-	B	E	-
X 500	9	A	C	E	B	E	F
	18	B	E	-	D	G	-
X 700	9	A	D	-	B	E	-
	18	B	E	-	D	F	-
X 800	9	B	E	-	D	F	-
	18	C	F	-	E	G	-
T 1000	9	B	E	-	D	F	-
	18	C	F	-	E	G	-
X 1020	9	B	E	-	D	F	-
	18	C	F	-	E	G	-
X 3050	6	D	F	-	F	G	-
	12	E	F	-	F	G	-

Table 4.1

		For cable lengths up to ...			
		20 m	50 m	100 m	200 m
Reference letter of table 1a	A	1,5	1,5	1,5	1,5
	B	1,5	1,5	1,5	2,5
	C	1,5	1,5	2,5	4
	D	1,5	2,5	4	6
	E	1,5	2,5	4	10
	F	1,5	4	10	16
	G	2,5	6	10	16
		Cross section (mm <sup>2</sup> )			

Table 4.2

## 4.5 Electrical Controls

Push button control for UP and DOWN.

On TIRAK® with two speed motor:

half-depressed	=	low speed
fully depressed	=	high speed.

**EMERGENCY-STOP button:**

Button depressed	=	mains supply interrupted.
------------------	---	---------------------------

To **START**, turn the EMERGENCY-STOP button clockwise until it releases.

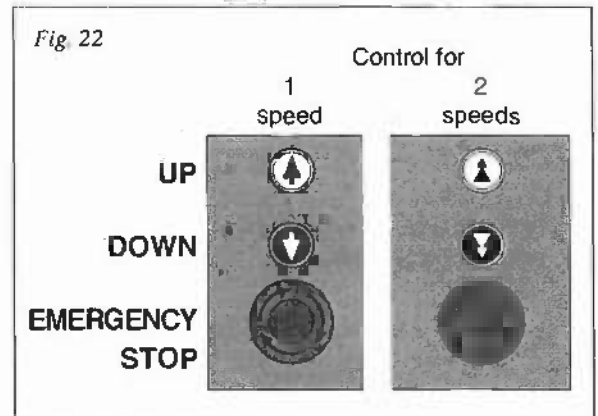

## 4.6 Wire rope installation

### 4.6.1 Preparing the wire ropes



**CAUTION!**

Use gloves, when handling wire ropes.

- Use only **TIRAK®** wire ropes specified by the TIRAK® manufacturer.
- Check **correct diameter** (Fig. 23) and **sufficient length** of the wire rope.
- Always **unreel** the wire rope in a **straight line** (Fig. 24), to prevent it from becoming unusable because of loops.
- Check the **rope condition** for damage:
  - Hook is **not bent**; safety catch is in place on the hook; proper connection between the wire rope and the hook (thimble, ferrule) (Fig. 25);
  - the wire rope has no visible damage along its total length; the fused and tapered end is according to Fig. 26.

e) **Attention!**



**Never use the TIRAK® wire rope for fixing the load!**

**Never let the wire rope rub over sharp edges!**

Always keep it lightly lubricated!

Always ensure a clear rope exit

**Important!**



If the anchoring point for the wire rope is **above** the TIRAK®.

**First anchor the wire rope, then insert it into the TIRAK® hoist.**

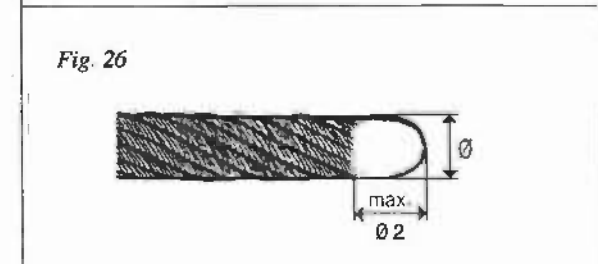
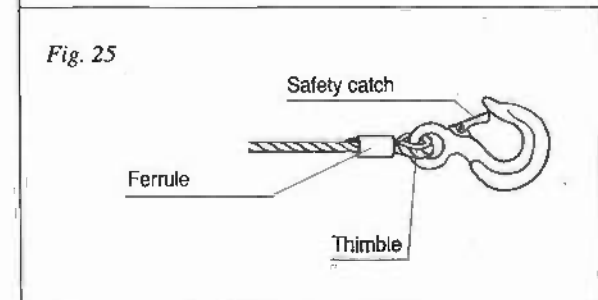
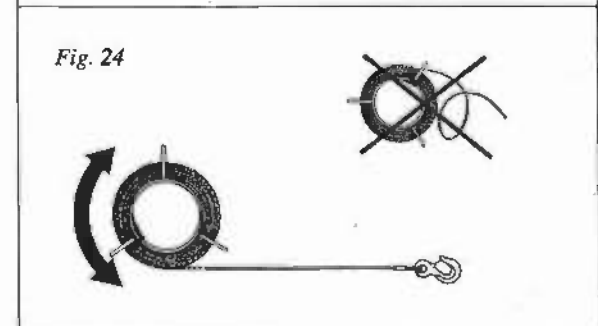
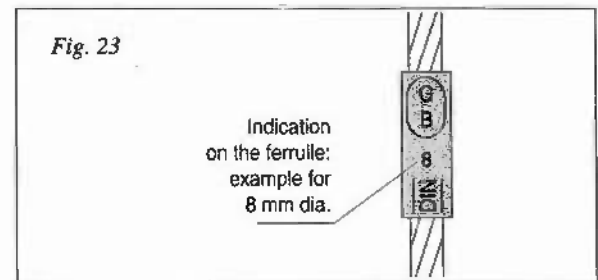

#### 4.6.2 Wire rope installation

##### A) TIRAK® series X 300 / 500 / 700 / 800 / 1020 / 3050

- Feed the wire rope as far as possible into the wire rope entry guide at the motor side only (Fig. 27).
- Press UP-button, and push in the wire rope, until it starts to reeve itself automatically and exits at the opposite side.

##### Attention!



Never use the DOWN button to install the wire rope, because the load limiting device will not function!

Ensure a clear rope exit (Fig. 27)!

- If the wire rope does not reeve, check:
  - Is the wire rope tip in good condition?
  - Did you press the correct button?



##### Attention on 3 phase motors!

Never operate the TIRAK with the phases reversed – turn the phase inverter of the plug by 180° (Fig. 28).

Fig. 27

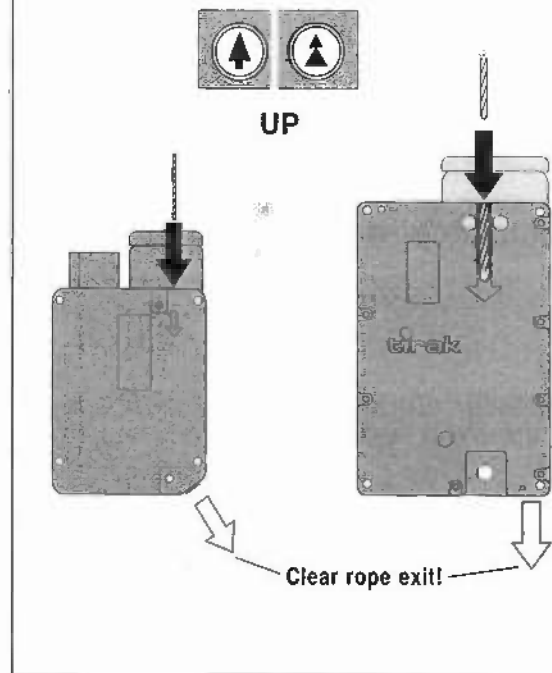
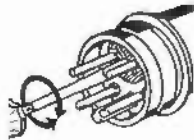

Fig. 28

Phase inverter  
in CE-plug



##### B) TIRAK® series T 1000

- On standard machines feed the wire rope as far as possible into the wire rope entry (A1) (Fig. 29a).

For special machines with inverted drive direction (see also chapter 4.2.2 on page 13) feed the wire rope as far as possible into the wire rope entry (A2) (Fig. 29b).

- Press UP-button, and push in the wire rope, until it starts to reeve itself automatically and exits at the opposite side.

##### Attention!



Never use DOWN button to install the wire rope, the load limiting device will not function!

Ensure a clear rope exit!

- If the wire rope does not reeve, check:
  - Is the wire rope tip in good condition?
  - Did you press the correct button?
  - Turn the phase inverter of the plug by 180° (Fig. 28).

Fig. 29a  
Standard machine

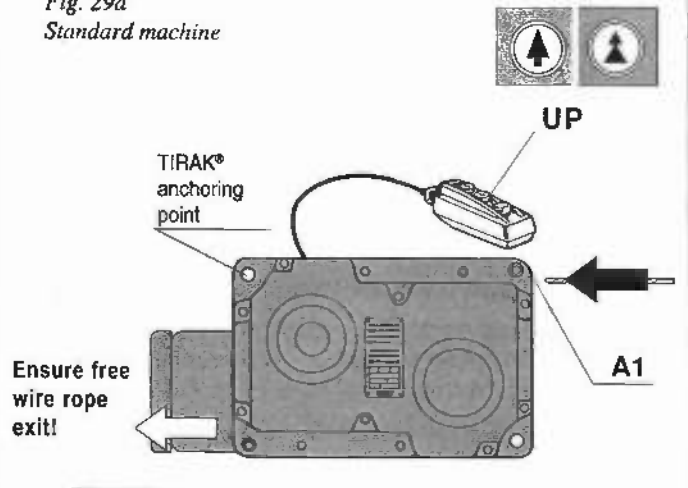
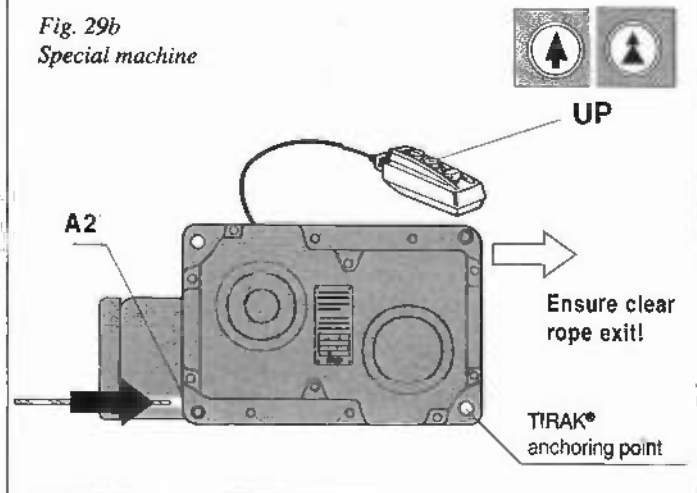

Fig. 29b  
Special machine





## 5. Operation

### 5.1 Checks before starting

- Check correct anchoring of TIRAK® hoist, pulleys and load.
- Check correct function of push buttons for **UP** and **DOWN** as well as **EMERGENCY STOP** (Fig. 30).
- Make sure, that no person is immediately below the suspended load.

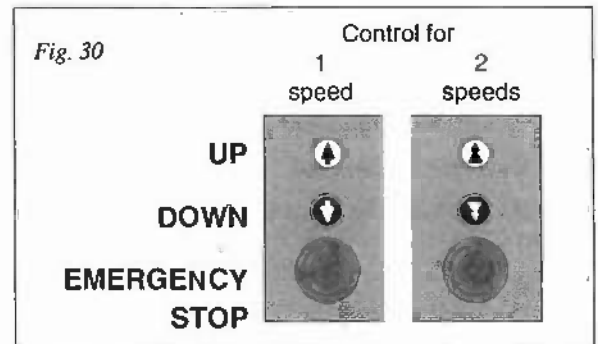

### 5.2 Weekly check of wire rope and cable



#### DANGER!

Damaged wire ropes endanger operational safety!

Therefore examine wire rope in accordance with section 8.2.1 on page 22 for damage which requires replacement.



#### Attention!

**Lubrication:** Keep the wire rope lightly lubricated. This will not affect the gripping power but will prolong the life of wire rope to a maximum.

Check all power supply and control cables and if necessary replace.

### 5.3 Operation

#### 5.3.1 Stop / EMERGENCY STOP (Fig. 30)

- To **STOP** movement release **UP-** or **DOWN-** button. The load stops.  
If not :
- Press **EMERGENCY STOP-Button**, the control must stop completely.  
if that does not function:
- Pull out the plug!**

**CAUTION!** in cases b) and c):



**STOP working.**  
Have the TIRAK checked/repared by a qualified electrician.

#### 5.3.2 Service Operation (Fig. 30)

- To **START**, turn the **EMERGENCY-STOP** button clockwise until it releases – it comes out and the control is ON.
- Lift/Pull:** press **UP**-button.  
**Lower/Release:** press **DOWN**-button.  
To **STOP**, release button (see also chapter 5.3.1).

Fig. 31

Phase inverter in CE-plug

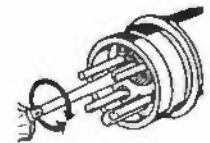

**Important:** If the hoist will not start, it might be possible that two phases of power supply are reversed so that the integrated phase control relay blocks the control.

**Correction:** turn the phase inverter of the plug by 180° (Fig. 31).

- When stopping the hoist the load is securely held at any position by the primary brake.
- Attention** must be paid to the load during all movements – if necessary by a second person.
- When lifting/lowering prevent the load from rotating (Fig. 32).  
If this is not possible, use a non-rotating wire rope with a ball-bearing swivel hook.
- When lowering/releasing watch the slack wire rope:
  - it has to be without damage;
  - it must not show loops (Fig. 33) or other deformations.
- Keep the wire rope lightly lubricated.

Fig. 32

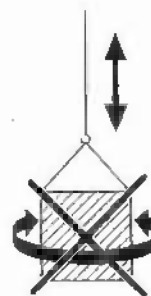
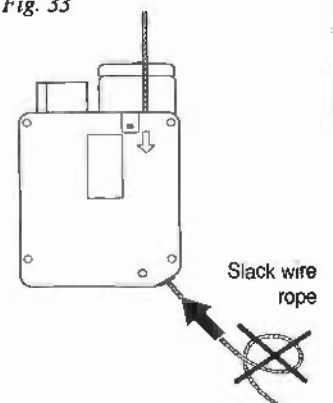

Fig. 33



## 5.4 Securing moving loads



### CAUTION!

Danger zone under moving loads must be cordoned off.

## 5.5 Manual operation

### 5.5.1 Emergency Descent

In case of power failure you can manually open the brake:

- Take the control lever (1) from the carrying handle, insert it through the motor cover into the brake release point, and raise it (Fig. 34). The TIRAK® starts running.
- Lower the load or let the TIRAK® descend along the wire rope with the load. The centrifugal brake limits the speed of descent.
- To **STOP**: release the control lever (1).
- After use: put back the control lever (1) in the carrying handle.

#### Attention!



Emergency descent in case of overloading is prohibited!

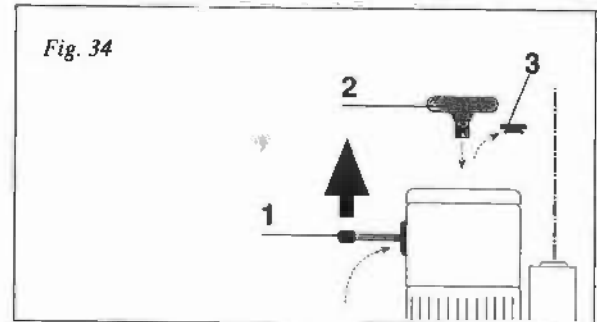

### 5.5.2 Manual lifting

- Take off rubber cap (3).
- Put the hand wheel (2) on the motor shaft and with the brake opened (see above) turn to the right (TIRAK® T...) or to the left (TIRAK® X...) to lift the load or let the TIRAK® climb the wire rope together with the load.
- After use: put brake release lever (1), hand wheel (2) and rubber cap (3) back to their original positions.









### WARNING!

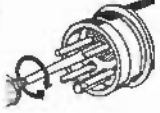

Avoid injuries:

- Checks and repairs of the electrical equipment must only be carried out by **qualified electricians!** Wiring diagrams are shown in the control box of the motor.
- Any other repairs should only be carried out by the manufacturer (or Group company) or by a qualified person, and only original spare parts shall be used.

## 6. Troubleshooting

Breakdown	Cause	Remedy
<p>Wire rope is not moving, although the motor starts when UP or DOWN button is depressed.</p> 	<p><b>STOP</b></p> <p><b>DANGER! IMMEDIATELY STOP WORK!</b> Any attempt to continue operating the TIRAK® hoist jeopardizes the operational safety!</p>	
	<p>A1 Wire rope stuck in the TIRAK® hoist. Defective or incorrect wire rope or <b>Obstructed wire rope</b> at the rope exit</p>	<ul style="list-style-type: none"> <li>Support the load (e.g. with a rope clamp and a lever hoist).</li> <li>Cut the wire rope with a bolt cutter at both sides of the TIRAK®.</li> <li>The TIRAK® must be repaired.</li> <li>If a substitute TIRAK® or other suitable hoist, e.g. a TIRFOR® is available: anchor a new wire rope, and install the substitute hoist to take the load. When the load is being fully supported by the substitute hoist remove the temporary supporting device and defective wire rope. Continue working.</li> </ul>
	<p>A2 The load has become caught on an obstacle or the load is tied down.</p>	<p>Carefully release load from the obstacle or untie. <b>Check wire rope, slings and load carrying device for their operational safety.</b></p>

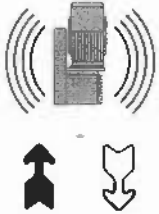
Breakdown	Cause	Remedy
<p>The hoist doesn't move at all.</p> 	<p><b>A3 Power failure</b></p> <p>a) Control switched off.</p> <p>b) Interrupted power supply.</p> <p>c) On 3-phase motors: two phases changed in the supply, the built-in phase control relay blocks the hoist control.</p> <p>d) Defect connection between power supply and hoist control.</p>	<p>a) turn the <b>EMERGENCY-STOP button</b> clockwise until it releases.</p> <p>b) Check reason and wait, until power returns.</p> <p>c) <b>Turn phase inverter</b> of the central control plug by 180°.</p> <p>d) Check lead and control cable, fuses and connections or wiring of central control and terminal boxes and repair if necessary.</p> 
<p> <b>DANGER!</b></p> <p>Always pull the plug out before opening a terminal box or a pendant or central control!</p>	<p><b>A4 Wrong connection,</b> e. g. no neutral conductor</p>	<p>Compare connection with wiring diagram. If necessary, conversion by the manufacturer.</p>
	<p><b>A5 Protective switching off due to overheating:</b></p> <p>a) One phase is missing</p> <p>b) Insufficient cooling</p> <p>c) Voltage too high/too low</p>	<p>a) Check/repair fuses/leads/connections.</p> <p>b) Clean air inlet at the motor cover.</p> <p>c) Check voltage and current consumption on the motor <b>under load</b>. If necessary increase lead cross section.</p>
	<p><b>A6 Brake does not open</b> (no "click" noise, when switching on/off)</p> <p>a) Defective supply conductor, brake coil, or rectifier.</p> <p>b) Worn brake rotor.</p>	<p>a) Have supply conductor, brake coil and rectifier checked by an electrician and repaired/replaced.</p> <p>b) Send the TIRAK® for repairs.</p>
<p>The hoist does not lift/pull, although descending/releasing is possible.</p> 	<p> <b>DANGER!</b> Thoughtless behaviour endangers the operational safety</p>	<p>Lower the load carefully and remove the obstacle.</p> <p>Check rope, slings or other load fixing devices and load carrying device for their operational safety.</p>
<p> <b>DANGER!</b></p> <p>Always pull the plug out before opening a terminal box or a pendant or central control!</p>	<p><b>B1 The load has become caught on an obstacle.</b></p>	<p>Check the load. If necessary reduce the load or use multiple sheave blocks. (see page 7 chapter 3.7).</p>
	<p><b>B2 Overload</b></p>	<p>Install wire rope again. Check why it had run out. Avoid repetition e. g. by use of a longer wire rope.</p>
	<p><b>B3 Wire rope completely run out</b> following lowering/slackening with unloaded hoist.</p>	<p>Check fuses and leads.</p>
	<p><b>B5 One phase is missing.</b></p>	<p>Check connections, wiring, contactors and replace if necessary.</p>
<p><b>B6 Error in the UP control circuit</b> of the TIRAK® hoist.</p>	<p>Check connections, wiring, contactors and replace if necessary.</p>	<p>Check connections, wiring, contactors and replace if necessary.</p>
<p>On single phase motors only</p>	<p><b>B7 lack of motor power</b></p> <p>a) Defective starting capacitor</p> <p>b) Defective centrifugal switch (starting capacitor overloaded)</p>	<p>a) Have starting capacitor checked/replaced by an electrician.</p> <p>b) Check the current at the auxiliary winding in the terminal box. Repair by the manufacturer or a hoist workshop.</p>

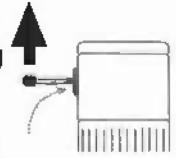
Breakdown	Cause	Remedy
<p>Excessive motor noise or hoist is crunching,</p>  <p>although UP and DOWN travel are possible.</p>	<p><b>C1 Overheating</b></p>	<p>Individual causes as well as their correction see page 19 point A5.</p>
	<p><b>C2 Dirt in the rope drive</b></p> <p><b>Attention!</b>   Continuing travel can lead to damage on the rope and the rope drive.</p>	<p><b>Replace the TIRAK® as urgently as possible and have checked/repared by the manufacturer or a hoist workshop.</b></p>
<p>The load can not be lowered, although it can be lifted.</p> 	<p><b>DANGER!</b> Thoughtless behaviour endangers the operational safety!</p> <p><b>D1 The load has hit an obstacle or has become caught on an obstacle.</b></p>	<p>Carefully lift the load, if necessary by manual lifting (see 5.5.2 on page 18) and remove the obstacle. Check rope, slings or other load fixing for their operational safety.</p>
	<p><b>D3 Error in the DOWN control circuit of the TIRAK® hoist.</b></p>	<p>If necessary <b>emergency descent</b> by inserting and pulling upwards the brake release lever. (see 5.5.1 on page 18)    Check connections, wiring, contactors and replace if necessary.</p>

**DANGER!**  
Always pull the plug out before opening a terminal box or a pendant resp. central control!

Should these steps not explain the cause and provide a remedy, contact GREIFZUG Hebezeugbau GmbH, an other company of the TRACTEL Group, or a hoist workshop.

## 7. Out of Operation

### 7.1 Temporary stoppage

- a) **Disconnect the power supply** to prevent any unauthorised operation:
  - Disconnect power supply cable from site distributor,
  - or, if available,
  - turn and lock the main switch to "0".
- b) **Cordon off the danger zone** below any suspended load.

### 7.2 End of Operation

- Run out the **wire rope** from the TIRAK® winch, clean and reel it.
- Disconnect the power supply cable from the site distributor. Check for any damage and reel the power supply cable.
- Disconnect the TIRAK® winch from its anchor point.
- Clean the exterior of the TIRAK®, and store it together with the wire rope in a clean and dry place.

## 8. Maintenance

Deadline (Performer)	Test item	Regulations	Details on page
Each working day: (Supervisor)	Anchoring parts <b>TIRAK®</b> hoists	UVV "Hoists" VBG 8	22
Each working week: (Supervisor)	Wire ropes Electric cables	VBG 9a, DIN 15020, part 2 —	22
Annually, at the latest however after 500 or 250 operating hours (Qualified person)	<b>TIRAK®</b> hoists	UVV "Hoists" VBG 8 EN 1808 (see above)	23

### 8.1 Maintenance

#### 8.1.1 Hoist

The mechanism does not require any special maintenance.

**Lubrication:** Keep the wire rope lightly lubricated. This will not affect the gripping power but will prolong the life of wire rope to a maximum.

#### TIRAK® series X 3050

##### Lubrication of the drive disks - outer toothing:

Replenish the reservoir behind the lubricating nipple every 50 operating hours with a grease gun (fig. 35).

Specification: Water-insoluble and thermoduric adhesive gear box grease,  
e. g. VARILUB

Quantity: two times approx. 5 cm<sup>3</sup>

- Prepare grease gun and press in first portion with 3 to 5 shots;
- Allow TIRAK® to run for approx. two seconds;
- Press in second portion.

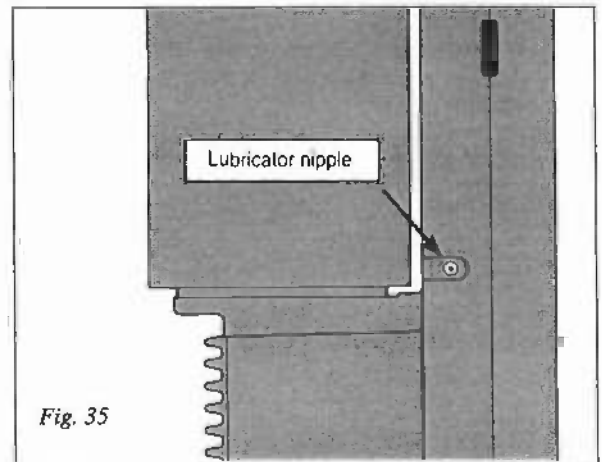

Fig. 35

#### 8.1.2 Wire ropes

- a) Always unreel and reel the wire rope.
- b) Do not use the wire rope for fixing a load, and do not pull it over sharp edges.
- c) Always keep the wire rope **clean and lightly lubricated**. Use normally commercially available multi-purpose grease; **do not use** lubricants containing disulphide (e.g. Molycote®).

#### 8.1.3 Motor, brake, and gear box

- a) The **motor** does not require any special maintenance. If it is **very dirty**, it should be cleaned to ensure an effective air flow.
- b) The **brake** does not require any special maintenance. If it is **very dirty**, it should be cleaned. **Keep it free of oil or grease!**
- c) The **gear box** is maintenance-free.

## 8.2 Checks

### 8.2.1 Essential checks

#### a) General

Prior to every operation  
and  
during operation make sure, that

- the TIRAK® hoist,
- and all other used equipment (anchoring devices, pulleys etc.)

are properly installed  
and  
without visible damage

#### Attention!



If during operation damage appears:

- STOP operating,
- if necessary: cordon off the danger zone, and
- have the damage removed by a qualified person!

#### b) Nameplates and labels

Make sure that all nameplates and labels are in place and not obscured (see section 9.4, pages 23 to 24).

Replace missing labels and those which are not legible!

#### c) Wire ropes

#### Attention!



Replace wire ropes, if one of the following defects is determined during the prescribed weekly check:

- 8 or more wire breaks (fig. 36) on a length which corresponds to 30 times the rope diameter.

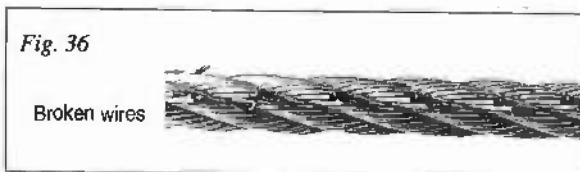

- Heavy rust formation on the surface or inside.
- Heat damage, recognisable through discoloured wires.
- Reduction of the diameter by 5% or more compared with the nominal diameter (fig. 38).
- External damage to the rope - fig. 37 shows the most frequent forms of damage.

These examples do not however replace the DIN 15 020, folio 2 reference for wire rope checks!

Fig. 37

"Pig-tail" curl  
in wire rope



Kinked wire rope



Damage  
caused by improper use,  
(e.g. by fixing the load with the rope)



Crushed wire rope



Birdcaged wire rope



Loop formation  
on wire rope

Fig. 38

Wire rope  
diameter

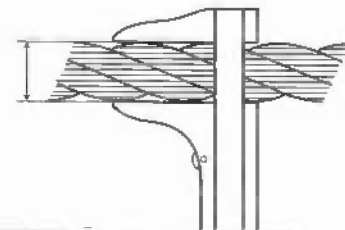

#### d) Electric cables

Replace lead and control cables if damage to the insulation or to cable connections is determined during the prescribed weekly check.

### 8.2.2 Safety Inspection\*

Checks by a competent person:

1. The TIRAK® should be thoroughly examined every twelve months or more regularly (see 2 below) depending on the working practice and current safety regulations in force.
2. The TIRAK® should be thoroughly examined at the latest after 500 running hours but for hoists with 18 m/min. and hoists of the series X 3050 with 12 m/min. speed after 250 running hours.



It is the responsibility of the employer that a **written register** is kept showing the dates, period of use and inspection record.

### 8.3 Repair

Repair of TIRAK® hoists must only be carried out by the manufacturer (or Group company), or by a qualified person and only original spare parts shall be used.

If a **gearbox oil change** is necessary, take one of the oils specified below according to the temperature range that the hoist will be usually used in.

Quantities required:

X 300 series:	1,4 l
X 500-1020 series:	2,0 l
T 1000 series:	2,0 l
X 3050 series:	5,0 l

Temperature range	-10 to +50 °C	-35 to +40 °C	-15 to +80 °C
API Specification	Mineral oils <sup>1)</sup> SAE85W-140 GL5 <sup>1)</sup>	Synthetic oils <sup>2)</sup> CLPPG or PGLP ISO VG 100 CLPPG or PGLP ISO VG 460 <sup>2)</sup>	
Sample oils (other oils on request)	BP Hypogear EP 90 SHELL Spirax HD 90 TEXACO Multigear EP6 S80 W90	BP Enersyn SG-XP 100 SHELL Tivela Oil SD 100 TEXACO Synlube CLP 100	BP Enersyn SG-XP 460 SHELL Tivela Oil SD 460 TEXACO Synlube CLP 460

1) Standard charge on series X 300 to 820 P and T 1020 P; also see foot note 3)!

2) Standard charge on series X 1030 to 2050 P

3) Important: Changing between mineral and synthetic oils requires the complete cleaning of the gearbox parts.

## 9. Spare Parts

### 9.1 Hoist

As well as the spare part number and description please always quote

- TIRAK® model
- wire rope diameter, and
- serial number.

### 9.2 Motor and brake

As well as the spare part number and description please always quote

- Motor type
- or
- Type and supply voltage of the brake.

### 9.3 Electric controls

In case of enquiries or spare parts order please always quote the

wiring diagram number.

The wiring diagram is situated in the control box of the motor.

### 9.4 Nameplates and labels

Make sure that all nameplates and labels are in place and not obscured (see fig. 39).

Replace missing labels and those which are not legible!

Spare parts lists are available from your supplier or from the manufacturer.

Fig. 39

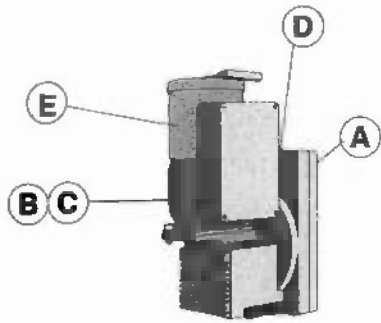

- A) TIRAK® nameplate
- B) Motor nameplate
- C) Brake nameplate
- D) Adhesive „Wire rope diameter“
- E) Adhesive „EMERGENCY STOP“

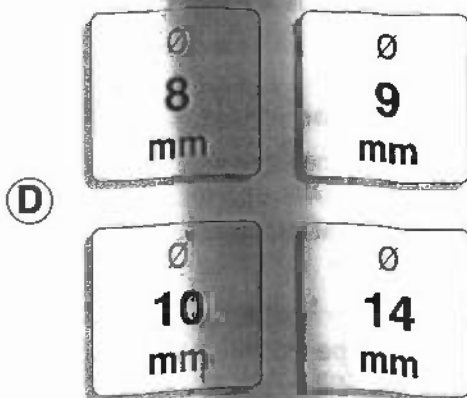
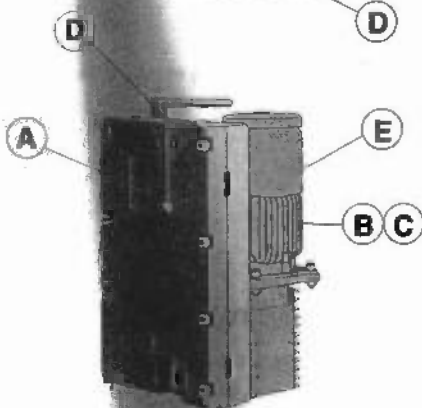
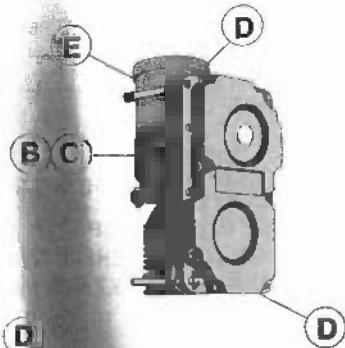

**A**

**tirak® Motorized traction machine**

**1. SET-UP INSTRUCTIONS**  
 Anchor the machine. Connect to electric/air supply (see motor name plate). Feed in the wire rope. Start the motor. Push wire rope inside, until it reeves itself automatically.  
**Do not obstruct the wire rope outlet!**  
 For details consult Operating Manual.  
**IMPORTANT: Use only special TIRAK wire rope in good condition with short fused and tapered end.**  
**Lightly lubricate the wire rope.**  
 Only TIRAK P models may be used for man riding. Use a BLOCSTOP® fall arrest device

**2. TECHNICAL DATA**

Model:	Capacity (daN/kg):
Admissible load for man riding (kg):	
Working speed (meters/min):	
Wire rope diameter (mm):	Breaking strength (kg):
Year of manufacture: <b>200</b>	Serial-No.:
In case of inquiry or spare parts order, please mention type, wire rope diameter, and serial number.	

**B**

**GREIFZUG GmbH** Bergisch Gladbach

Type	Nr.	
E-Mot.	60 Hz	U <sub>nom</sub>
	kW	cos φ
	V	A
Schall.	Schutzart IP 55	F Is Ki

**C**

**GREIFZUG GmbH** Bergisch Gladbach

Bremstyp	
Leistung	W
Moment	Nm
Spulenspannung	V

**E**

**Notablaß**  
 Bremslöserhebel im Handgriff  
**Emergency Descent**  
 Brake release lever in TIRAK handle  
**Descente d'urgence**  
 Manette de commande du frein dans la poignée de portage

G 207-09/94



## Suitable accessories

Details on request

### Wire rope guiding spring

- to divert the slack wire rope end

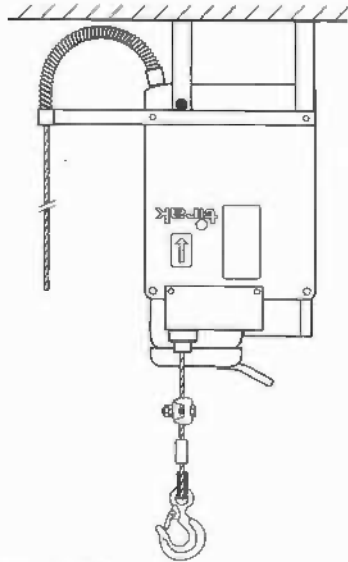

### Limit switch

- for cutting off the lifting/pulling movement

### Wire rope storage devices

- automatic rope reeler for wire rope lengths up to 80 m (see fig.)
- driven wire rope drums for wire rope lengths up to 500 m

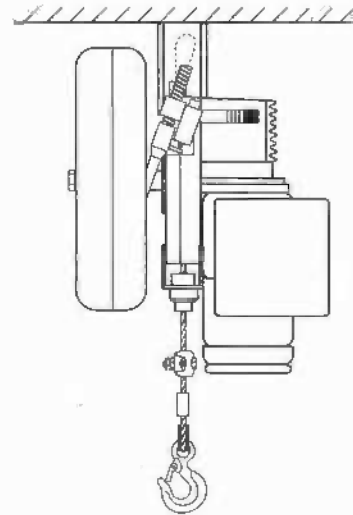

Wire rope storage capacity up to 500 m are offered by the "Mobile winches with the TIRAK®" shown on page 26.

### Suspension on beam trolleys

- for the lateral movement of the TIRAK®;
- with plain, geared or electric driven trolleys;
- the picture shows a hoist equipped with wire rope guiding device and automatic wire rope reeler.

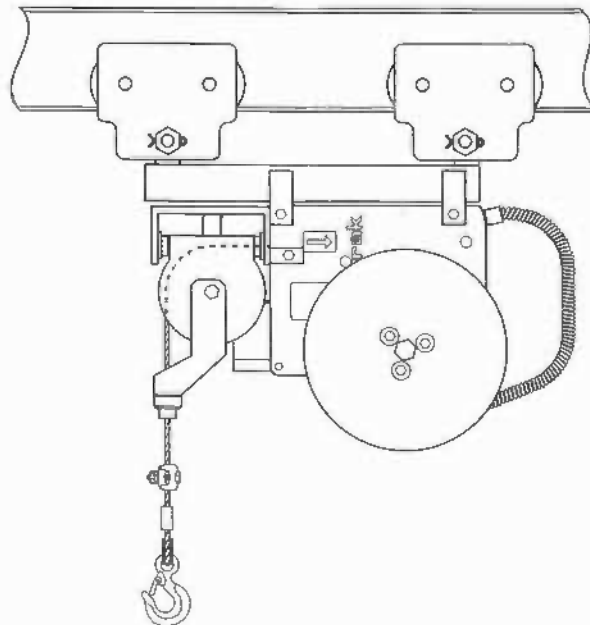

## TIRAK® as "Mobile Winch"

### TIRAK® with rope storage for rope lengths from 80 to 500 m



300 kg hoist with  
80 m rope reeler

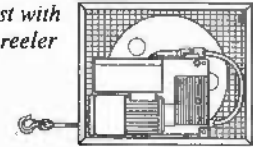

- The ideal hoist for frequently changing places of use.
- Quick, simple, versatile:
  - Assembly on construction site.
  - Repair and maintenance work in finished buildings.
  - Drive for internal transport systems.

3 t hoist with  
500 m rope winder

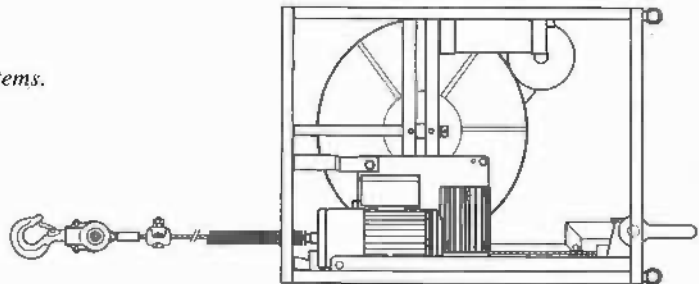

### Saves space, weight and costs

compared to a crane  
or drum winch of the  
same carrying capacity and range!

Details on request

## TIRAK® hoists for man riding applications

### The ideal hoist for "Suspended Access Equipment"

- Unlimited travel height.
- Maximum capacity of the man-riding equipment due to the minimum weight of the hoist.
- CE approved.

In addition we offer **BLOCSTOP®**  
fall arrest devices, which act as a  
secondary brake on a separate  
safety wire rope.

Capacity  
0,3 to 2 t

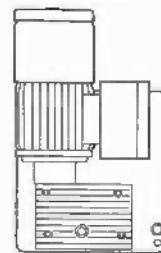

300 kg hoist

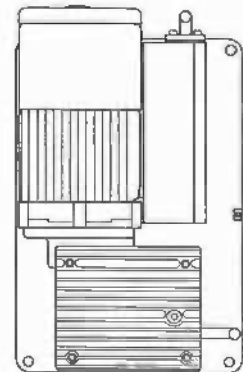

2 t hoist

Details on request

### Series XS 300 P for silo inspection

These devices conform to the special safety requirements applicable for inspecting silos:

- Hand operation,
- hanging limit switch for the manual operation when passing through the silo opening.

The device illustrated is equipped with an automatic rope reeler for a 40 m rope.

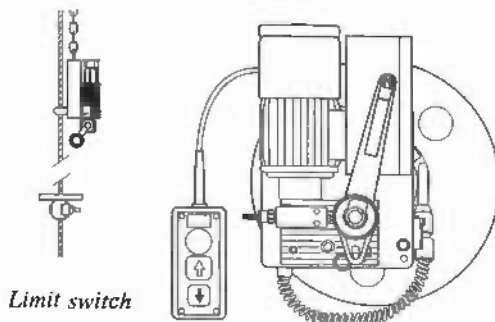

Limit switch

Details on request.

## Access solutions from the TRACTEL Group

### Suspended platforms, working cage & seat

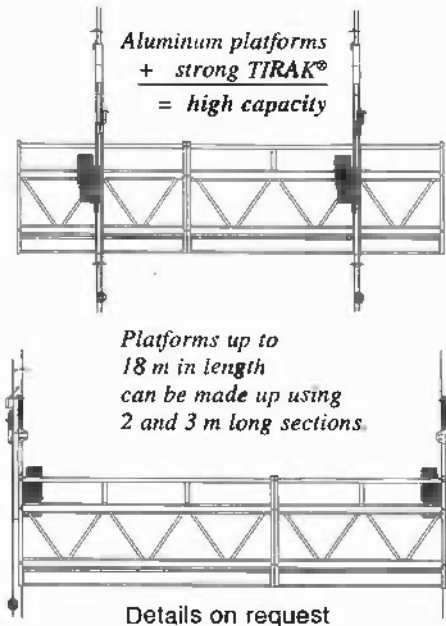

*These new, mobile platforms and seats with unlimited travel height for assembly, inspection and repairs offer you the comfort of a lift combined with a working platform.*

*Whether you have to work at height as facade designer or window cleaner, as insulation specialist, as chimney, boiler and tank setter or as painter and corrosion protection personnel:*

*Make use of this sensible replacement for standing scaffolding! Travel to height, and indeed to precisely that height which gets you to the most productive working position. Because that helps to save time and money!*

*Increase your competitiveness by reducing operating costs.*

*That improves the bottom line!*

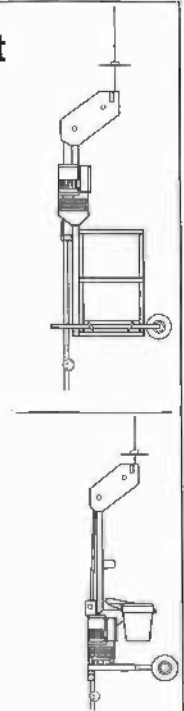

**Whether purchased or rented – the economic alternative to scaffolding!**

### Building maintenance and inspection installations

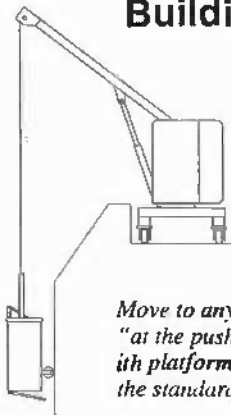

*Modern, daring building constructions demand creative solutions.*

*The earlier you involve our team in your planning the easier and cheaper the installation will be!*

*Move to any position of the facade "at the push of a button" – with platform and roof car, the standard solution.*

*For inspecting building constructions outside and inside – with platforms which move on rail systems.*

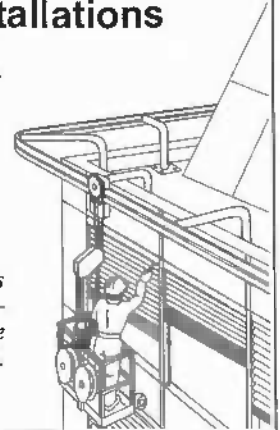

### Moveable stairs and work gantries

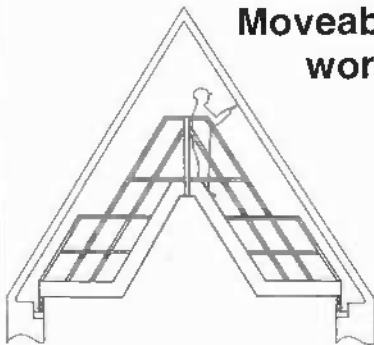

Details on request

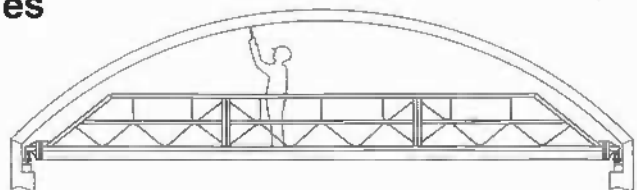

*For cleaning, inspecting and repairing windows, facades and glass roofs, inside and outside.*

**Let your buildings always shine!**

# The TRACTEL Group safety package

## TRAVSAFE® – horizontal travelling lifeline system

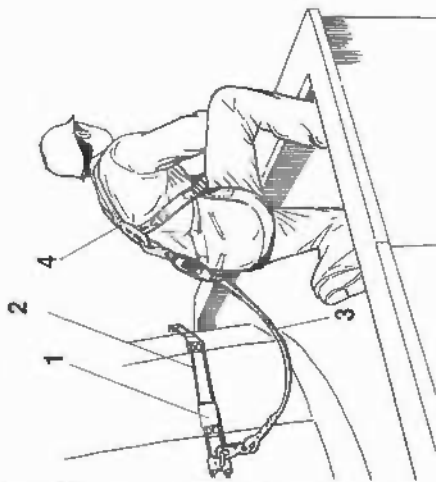

TRAVSAFE® is a patented horizontal running protection system for working at heights in which there is a risk of falling.

Areas of use: buildings and roofs, aircraft hangars, shopping centres, bridges and viaducts, industrial installations, overhead cranes, oil and gas containers, telecommunication towers ...

The TRAVSAFE® system consists of two wire ropes along which a traveller (1) slides. These lifelines are held by brackets (2) anchored to the building. The user anchors the connection devices (3) of his personal protective equipment (4) to the holding ring of the traveller.

The TRAVSAFE® travelling lifeline enables free and unhindered movement and work.

TRAVSAFE® systems require thorough planning and professional installation – challenge us to provide extensive advice.

**Gives a sure hold,  
just where you need it!**

© GREIFZUG GmbH 2000

## Fail arrest equipment for personal protection

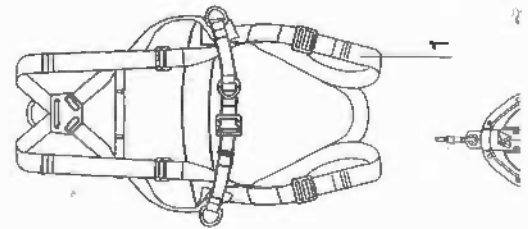

For all work in which there is a risk of falling "Safety first" is the overriding objective. The appropriate equipment must be put together depending on the location and work to be performed. The product range of our safety program offers the following, amongst other things:

- Harnesses and working belts, also as a practical combination (1)
- retractable lifelines (2)
- rope grabs (3)
- climbing protection devices
- retaining ropes
- lanyards (4)
- shock absorber (5)
- various connectors

For common applications we offer

